

# Product Dimensions

# Cut-Out Dimensions

Sunstone Metal Products  
 16004 Central Commerce Dr  
 Pflugerville TX 78665  
 Tel: 888.934.9449  
 Bus: 512.487.5116  
 Fax: 512.487.7016

**PRODUCT**  
**30" X 6-1/2" PREMIUM DRAWER**  
 Item No. A-SD30

**DESCRIPTION**  
 This 30 Inch Barbecue Island Drawers with Removable Space Divider, Constructed of commercial grade 304 Stainless Steel with heavy duty rails to ensure easy opening and closing, providing abundant space. Great for Outdoor Kitchen.

30"W x 6.5"H x 25"D (Product Size )  
 28-3/8"W x 4-3/4"H x 22-7/8"D (Cut-out )  
 42 LBS (Product Weight)

**Material Specifications:**  
 18 gauge 304 stainless steel for frame.  
 20 gauge 304 for drawer cabinet.  
 18 gauge galvanized sheet for the box.  
 Handles are made of zinc alloy, chrome plated.

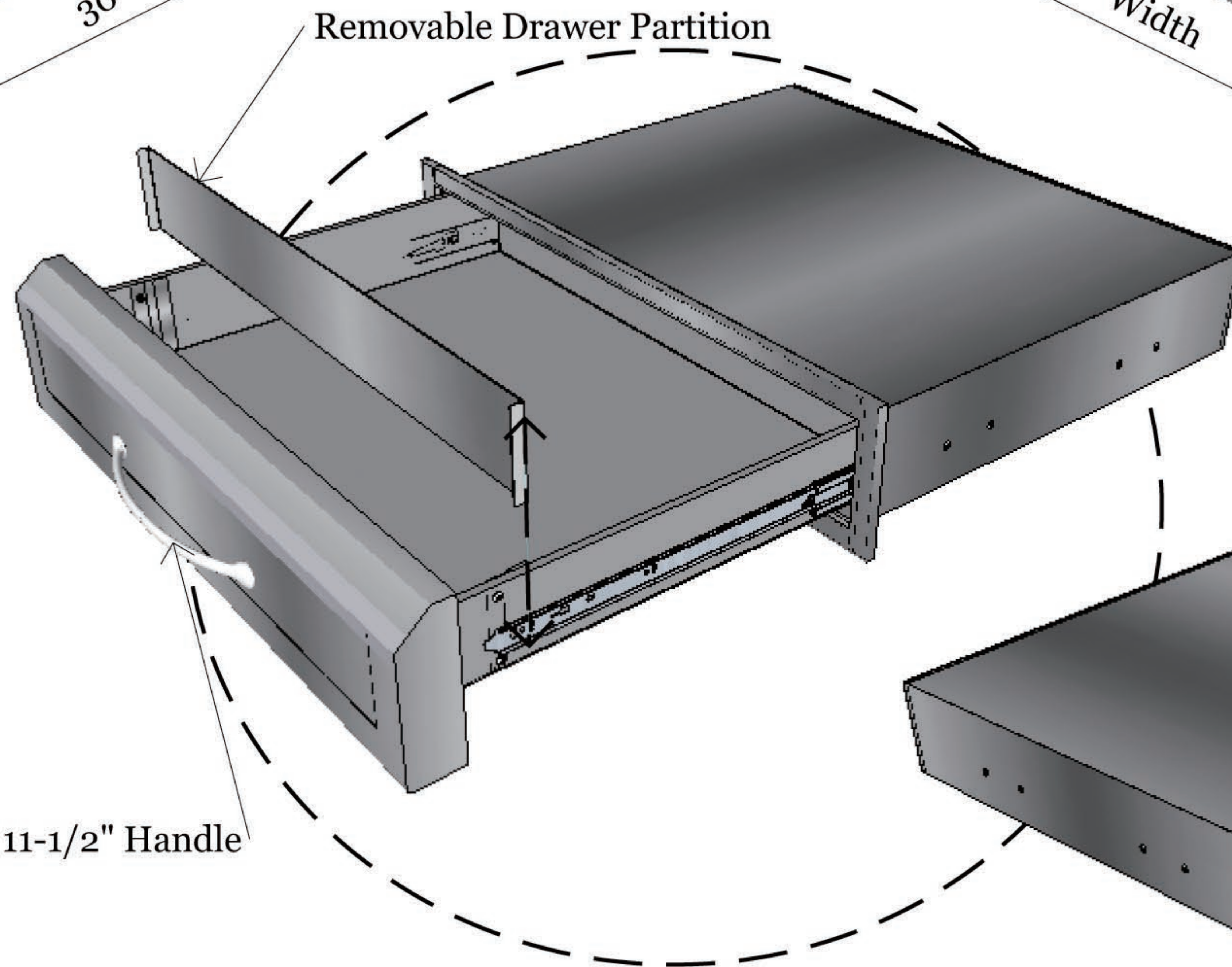
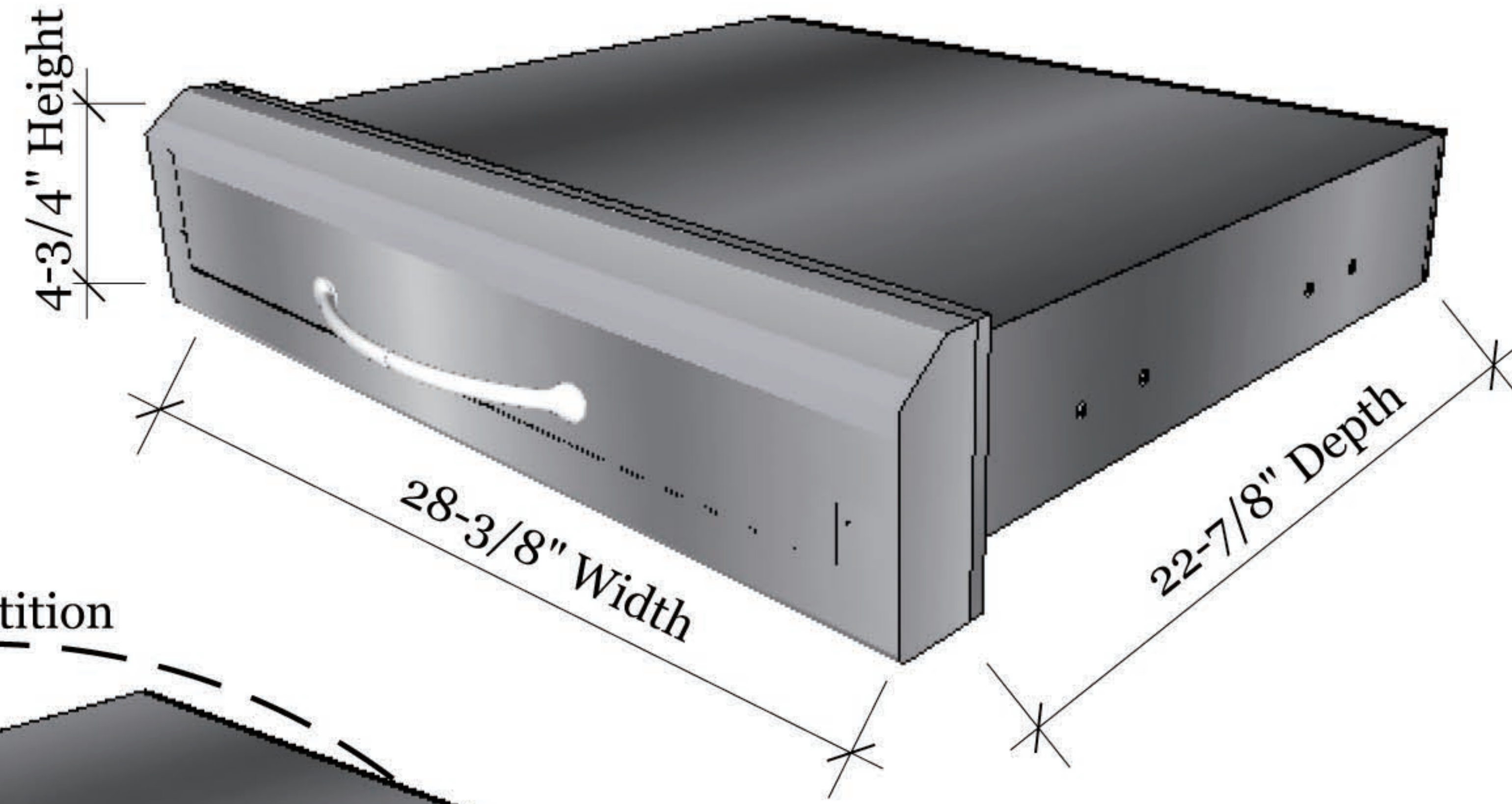
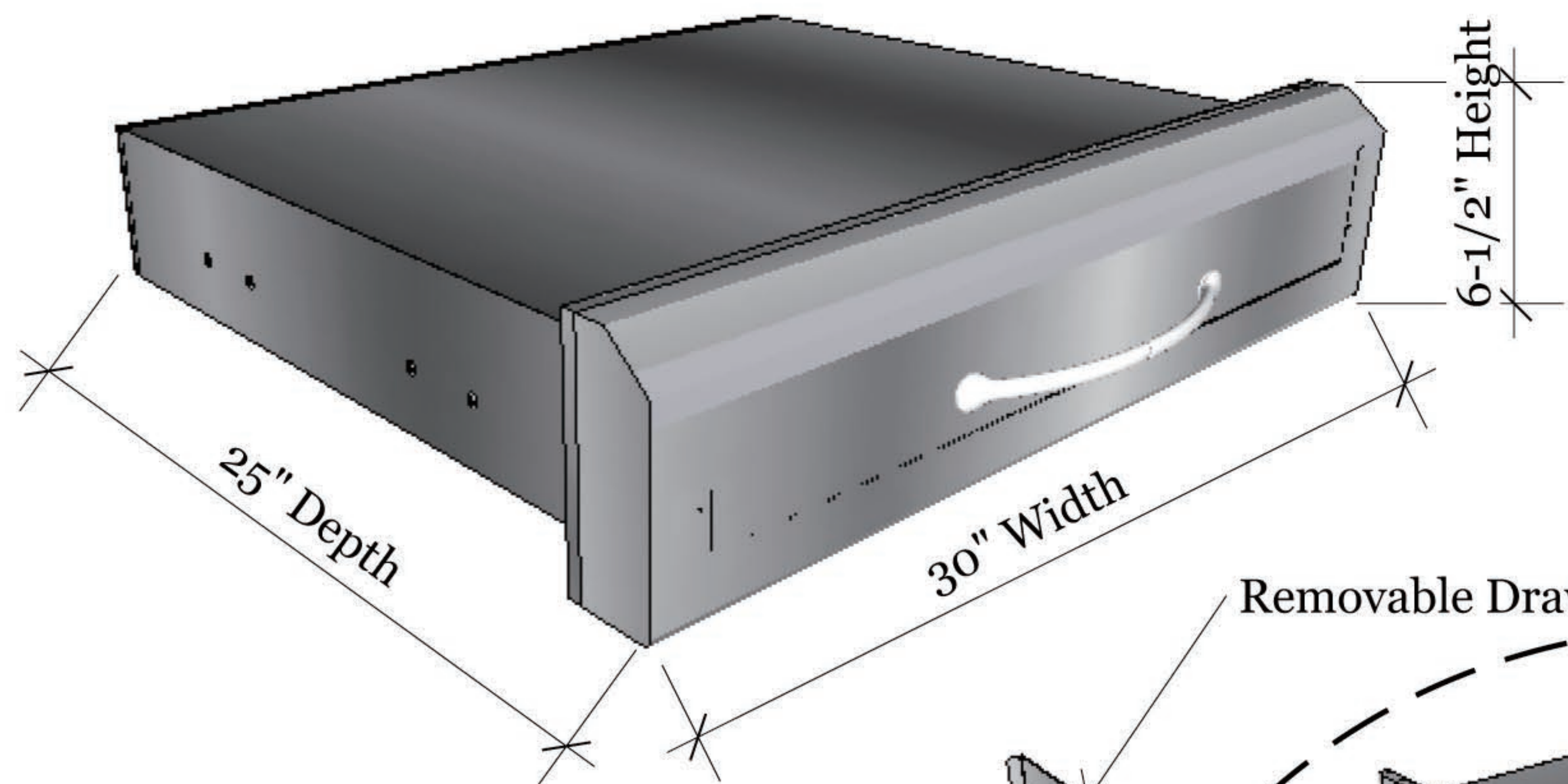

1-7/8" Drawer Face Depth



**Drawer Depth**

2-1/2" Total Depth w/Flange

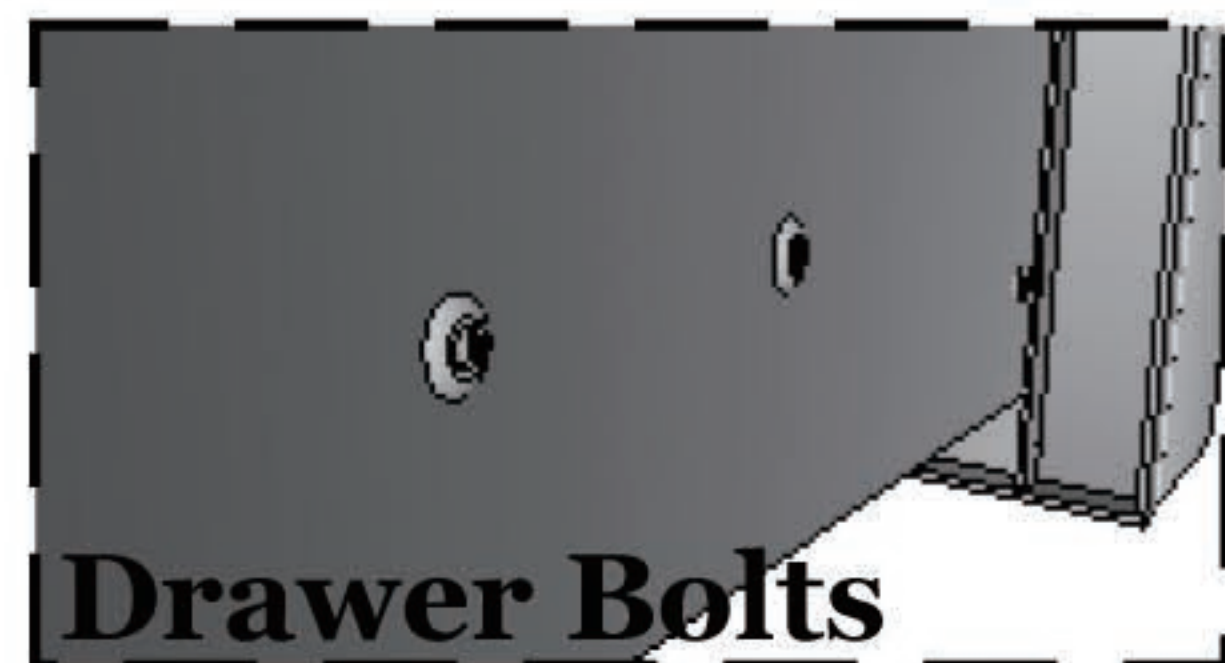

**Drawer Bolts**

Large 11-1/2" Handle

23" Deep Drawer Space

27" Wide Drawer Space

**Use as Storage for all your BBQ Accessories and Silverware**

**Food Preparation items and Paper Towels**



**Drawer Flange**

1" Flange

4" Depth

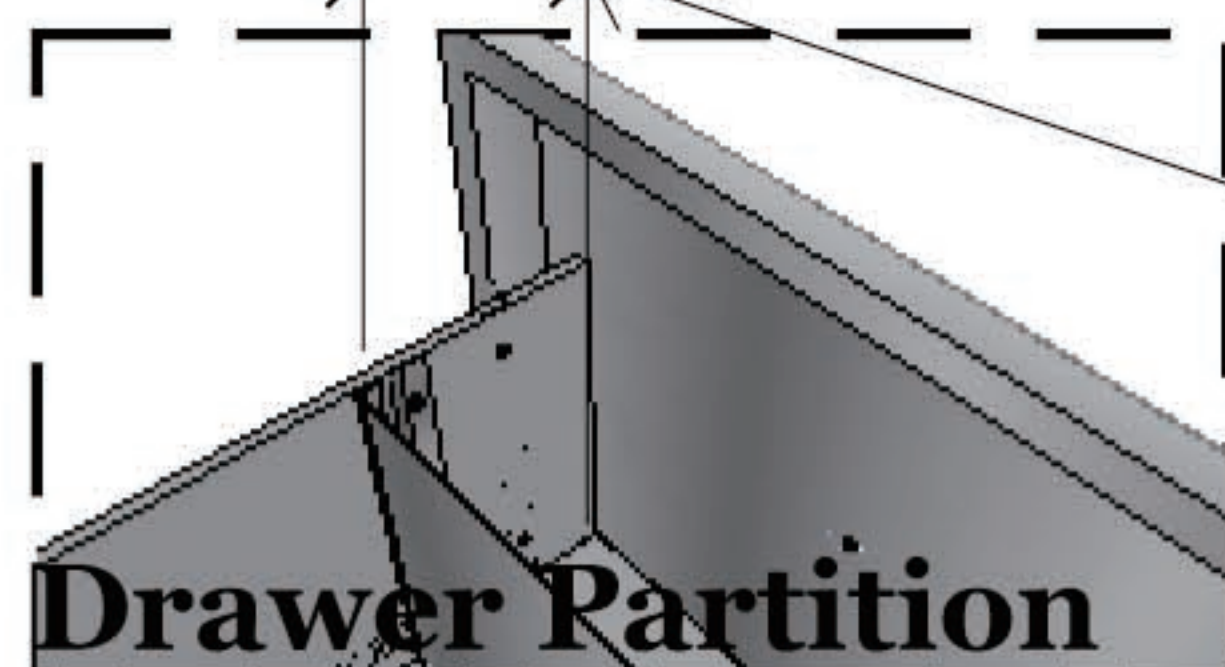

**Drawer Partition**

4" Inside Drawer Pocket, with Removable divider

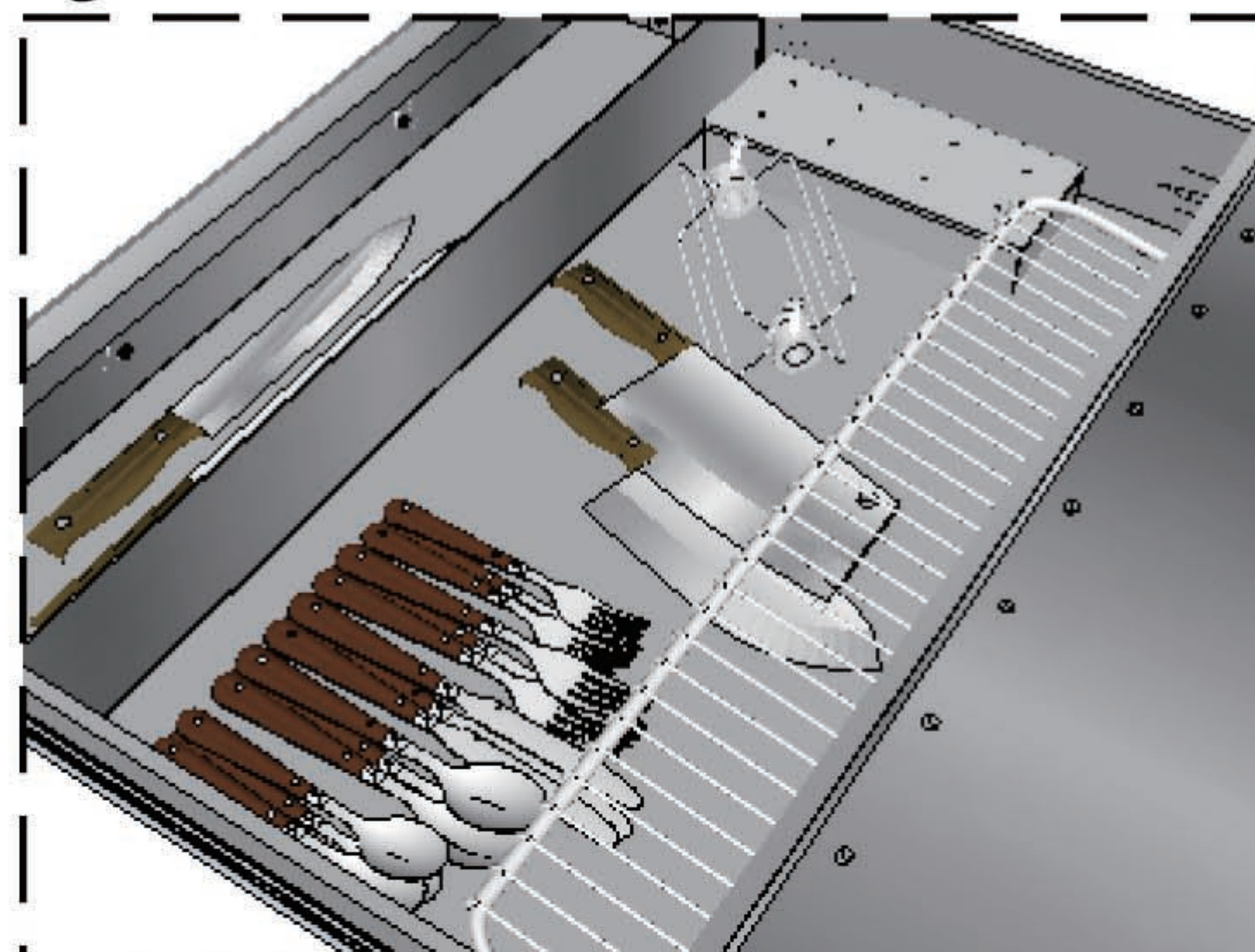

Two Drain Holes under Drawer front Face

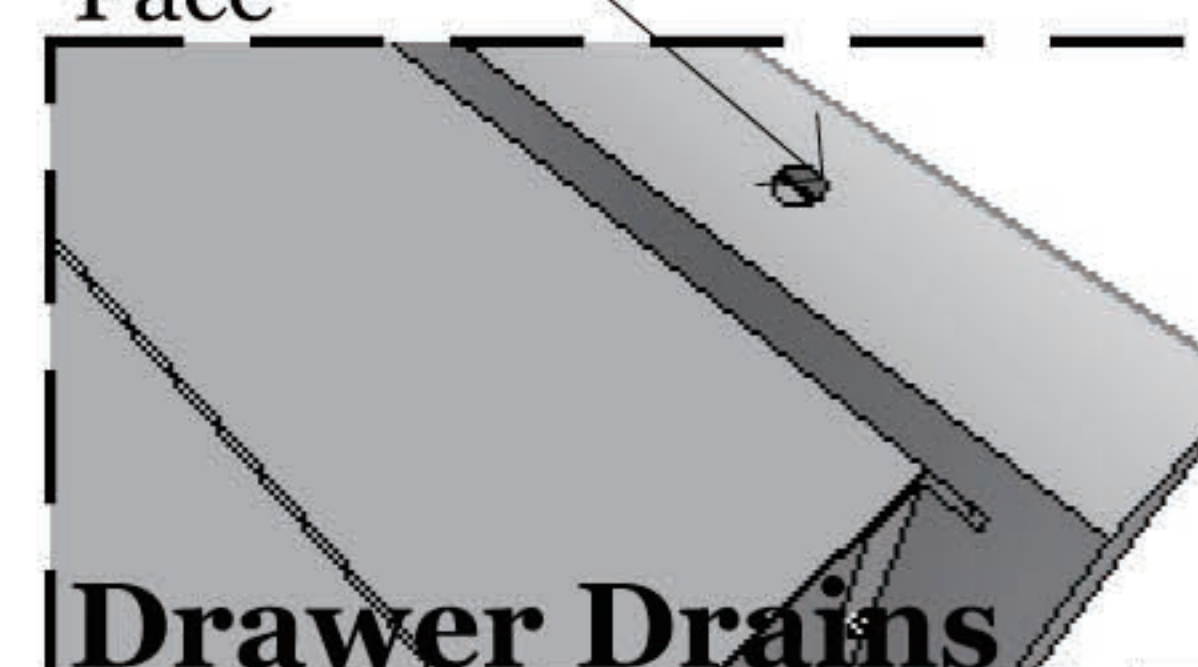

**Drawer Drains**

