

6.0 CU. FT. BEER KEG REFRIGERATOR

ZPJ-170

SAFETY PRECAUTIONS

Read all of the instructions before using this appliance. When using this appliance, always exercise basic safety precautions, including the following:

1. Use this appliance only for its intended purpose as described in this operation manual.
2. This appliance must be properly installed in accordance with the installation instructions before it is used. See the installation section for more details.
3. This appliance must be connected to a proper electrical outlet with the correct electrical supply.
4. Proper grounding must be ensured to reduce the risk of shock and fire. Do not cut or remove the grounding pin! If you do not have a three-prong electric receptacle outlet in the wall, have a certified electrician install the proper outlet. The wall receptacle must be properly grounded.
5. Never unplug your appliance by pulling on the power cord. Always grasp the plug firmly and pull straight out from the outlet.
6. Immediately replace worn power cords, loose plugs and power outlets. If the supply cord is damaged, it must be replaced by the manufacturer or its service agent or a similarly qualified person in order to avoid a hazard.
7. To reduce the risk of electric shock or fire, do not use extension cords or adapters to connect the unit to an electrical power source.
8. Unplug your appliance before cleaning or making any repairs.
9. We suggest that a certified technician perform the service if for any reason this product requires service.
10. If your old appliance is being discarded, we recommend that you remove the door and leave the shelves in place. This will reduce the possibility of danger to children.
11. This appliance should not be recessed or built into an enclosed cabinet. It is designed for freestanding installation only.
12. Do not operate your appliance in the presence of explosive fumes.
13. Do not tamper with the controls.
14. Do not operate this appliance when parts are missing or broken.
15. Do not use this appliance for commercial use.
16. This appliance is designed for indoor use only and should not be used outdoors.
17. To reduce the risk of injury, do not allow children to play in or on the appliance. Close supervision is necessary when the appliance is used near children.
18. The appliance door must be closed during operation. Do not leave the door open when children are near the dispenser.
19. Do not run cord over carpeting or other heat insulators. Do not cover the cord. Keep cord away from traffic areas, and do not submerge in water. DO NOT attempt to operate this unit with a damaged cord or plug.
20. DO NOT roll the beer keg fridge with loaded beer kegs on carpet floor.
21. This appliance is not intended for use by young children or infirm persons without supervision.
22. This appliance is NOT A TOY!
23. Young children should be supervised to ensure that they do not play with this appliance.
24. When transporting the refrigerator, keep the unit in the upright position. Do not tilt the appliance beyond 45° or place the unit in upside down position.

IMPORTANT SAFETY PRECAUTIONS OF CO₂ (CARBON DIOXIDE) GAS

1. CO₂ gas can be dangerous! CO₂ cylinders contain high - pressure compressed gas, which can be hazardous if not handled properly. Make sure you read and understand all the procedures for the CO₂ cylinders before installation.
2. Always connect the CO₂ cylinder to a regulator! Failure to do so may cause an explosion resulting in possible death or injury when the cylinder valve is opened,
3. Never connect the CO₂ cylinder directly to the product container.
4. Always follow the correct procedures when changing cylinders.
5. Never drop or throw a CO₂ cylinder.
6. Always keep CO₂ cylinders away from heat. Store extra cylinder at a cool place (preferably lower than

- 70° F). Secure fasten with a chain in an upright position when storing.
7. Always ventilate and leave the area immediately if CO₂ leakage has occurred!
8. There are two safety devices in the pressure system in the form of a valve. One safety feature is on the CO₂ bottle. The second is on the regulator.
9. Never attempt to refill CO₂ cylinder yourself. CO₂ tanks can be refilled at locations such as welding supply shops, party stores, fire supply shops, or where kegs are purchased.

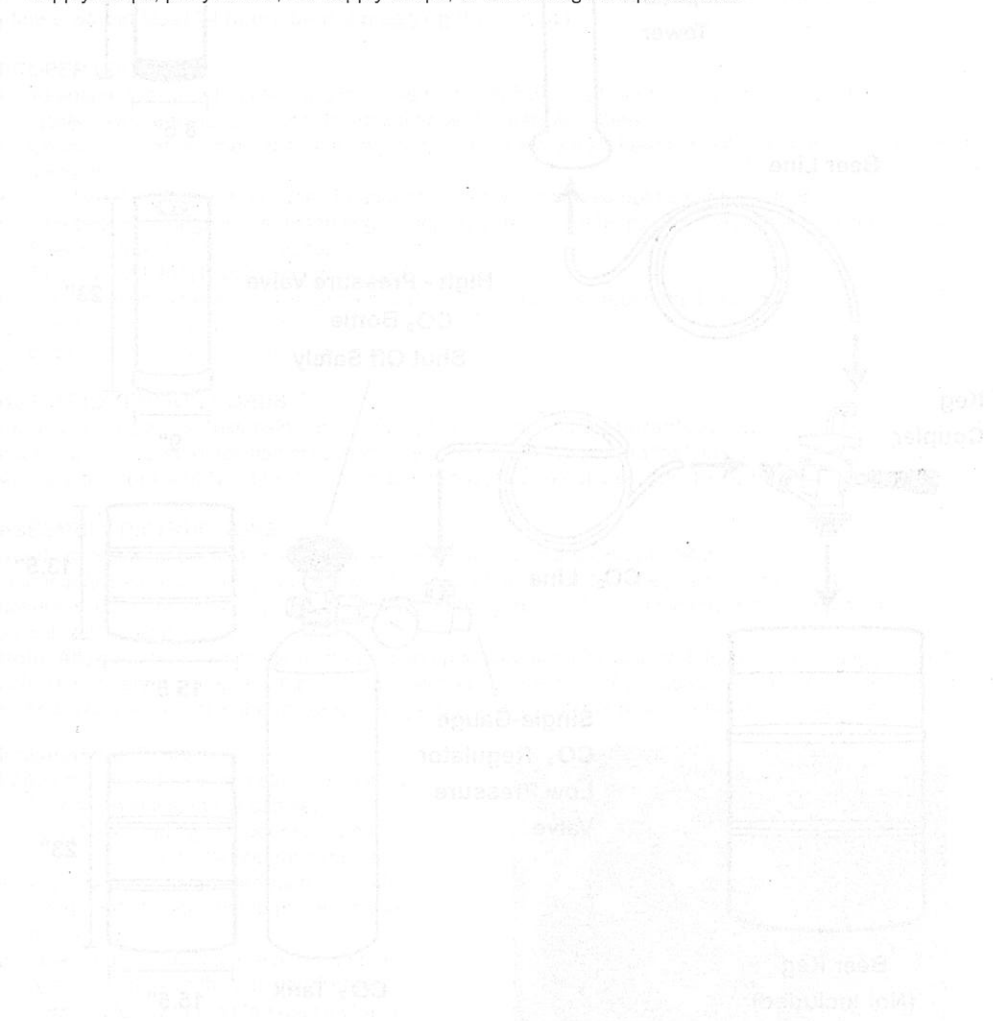

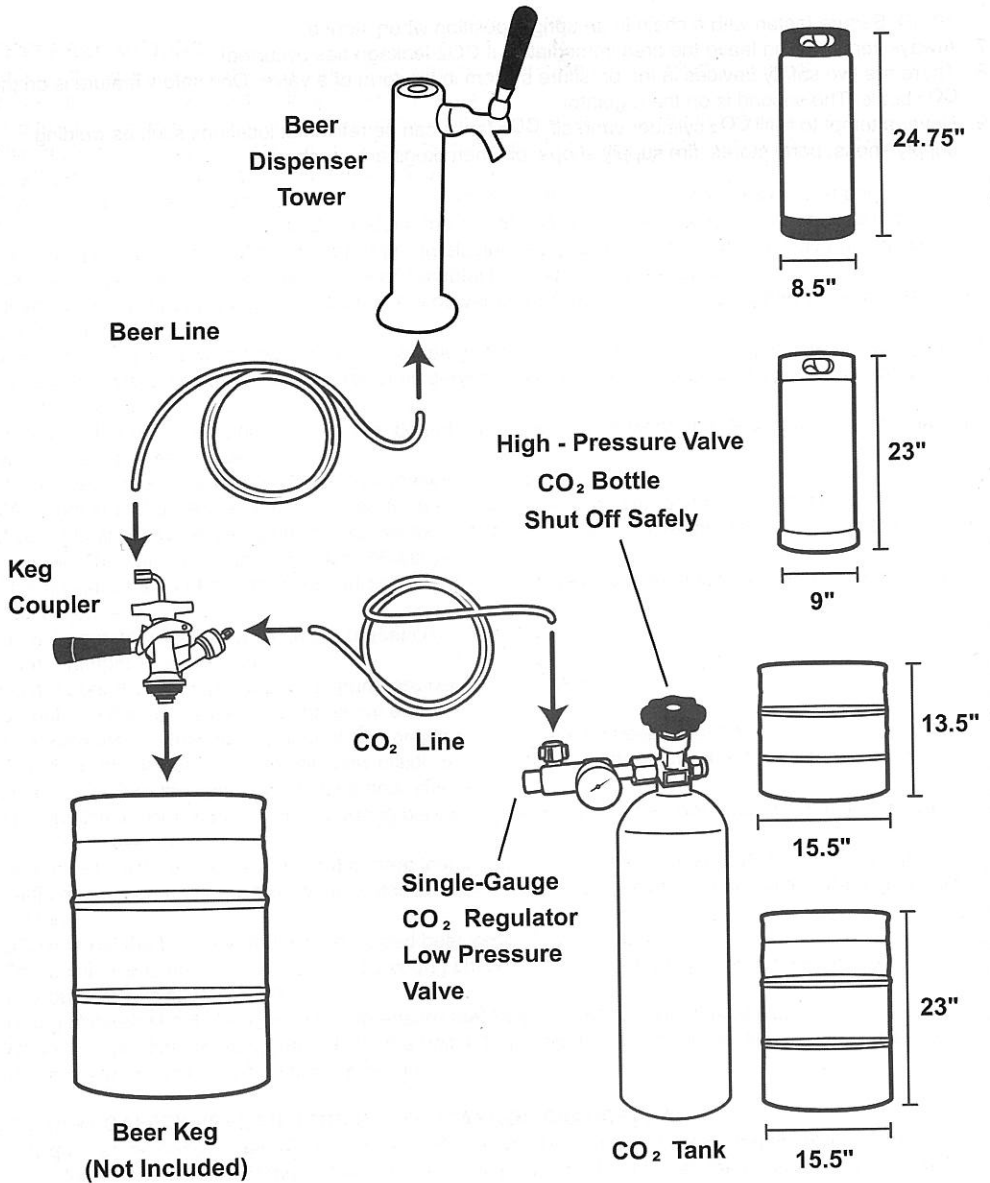

SAVE THESE INSTRUCTIONS FOR FUTURE USE

DANGER!

Risk of child entrapment! Before throwing away your old appliance, remove the door so that children may not easily become trapped inside.

- Take off the doors.
- Leave the shelves or other accessories in place so that children may not easily become trapped inside.

(Note: If the refrigerator has been placed in a horizontal or tilted position for any period of time, please wait at least 24 hours before plugging the unit in.)

PROPER LOCATION

- To ensure that your beer keg fridge works to the maximum efficiency it was designed for, keep it in a location where there is proper air circulation and electrical outlets.
- Choose a location where the beer keg fridge will be away from heat and will not be exposed to direct sunlight.
- This beer keg fridge is designed for indoor use only -- it should not be used outdoors.
- This beer keg fridge is a freestanding design and should not be placed in a built-in or recessed area.
- Beer keg fridge unit dimensions:
21.3" W x 33.20" H (with casters) x 26.60" D
- The following dimensions are recommended for clearances around the beer keg fridge:
Sides : 5" (12 cm)
Back : 5" (12 cm)

USE OF EXTENSION CORDS

Always avoid using an extension cord because of potential safety hazards in certain conditions. If it is necessary to use an extension cord, use only a 3-wire extension cord that has a 3-blade grounding plug. And use the cord with No. 14 AWG minimum size and rated not less than 1875watts.

ASSEMBLY INSTRUCTIONS

Read assembly instructions carefully to ensure that you understand all installation instructions before installing the beer keg fridge. If after completing the process you are still unsure whether the beer keg fridge has been properly installed, we recommend that you contact a qualified installer.

Note: Allow the beer keg fridge to stand in an upright position for at least 8 hours before plugging in the unit. This is very important! Once the unit is laid on its side, the refrigeration in the refrigeration system is shifted. The refrigerant in the refrigeration system needs to stabilize before the unit is turned on.

Installing the Casters

Follow the steps below to install the casters.

1. Empty the inside of the cabinet completely and lay the beer keg fridge down on it's side. We recommend that you place a piece of cardboard or cloth underneath the cabinet to prevent dents or scratches.
2. Insert the casters into the holes on the bottom corners of the cabinet. Tighten each caster by turning the nut clockwise with a wrench (not provided in the kit).
3. Once all four casters have been tightened, stand the cabinet in its upright position.

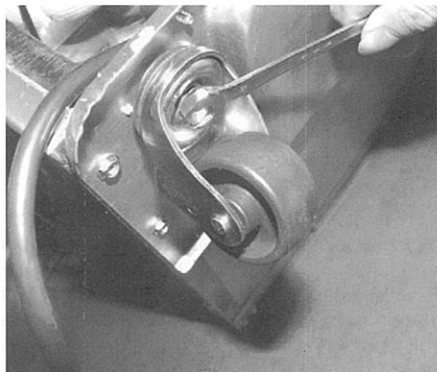

Note: Two of the casters include locking mechanisms

to ensure the unit does not slide on hard floors. These two locking casters should be fastened at the front

end of the unit, with the unlocked casters fastened on the rear end.

INSTALLING THE BEER TAP

Follow the steps below to install the beer tap. There are notches on the bottom of the draft arm assembly that line up with grooves inside the opening on the top of the beer keg fridge. Align the draft arm with the opening on the top of the unit, then place inside and twist until secure. No screws are necessary, it locks into place simply.

Pay attention to use the thin black gasket for assembly. (See Illustrations C & D on following page)

Also, See Illustrations E & F on following page, showing the hose connections to CO₂ regulator and the regulator to the beer tap.

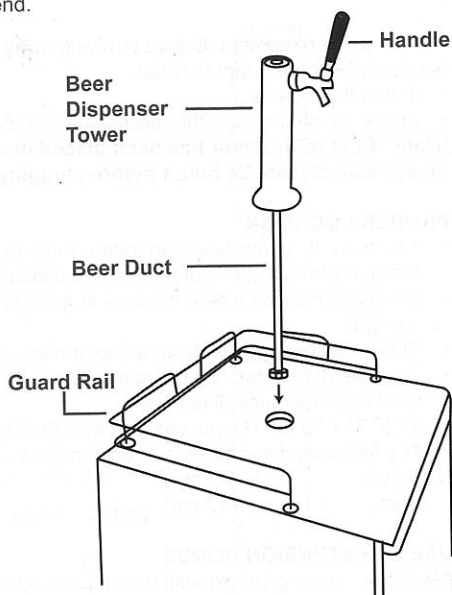

INSTALLING THE GUARDRAIL

Follow these steps below to install the guardrail.

1. Place the guardrail on top of the cabinet.
2. Align all support feet of the guardrail with the holes of on the top of the unit.

INSTALLING THE CO₂ REGULATOR AND THE CO₂ CYLINDER

Follow these steps to safely install the CO₂ regulator and CO₂ cylinder. You must read and understand the following procedures for the CO₂ cylinders before installation.

NOTE: Your CO₂ cylinder has DOT (USA Department of Transportation) approval, however the cylinder has been shipped empty to avoid any possible accidents during transportation. When you purchase the first keg of beer, you must also have your CO₂ cylinder filled at your local supplier. (See page 2, item 9 for suggested locations within your community.)

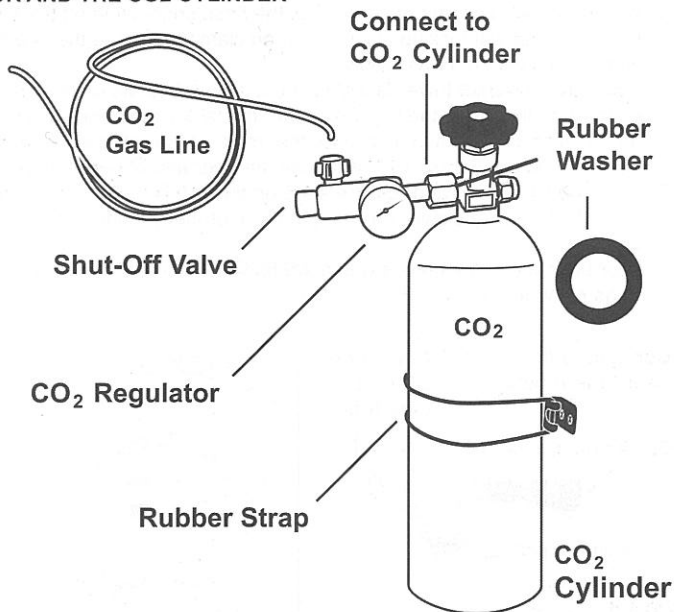

1. Install the CO₂ gas line tube to the regulator by attaching one end of the tube to the hose barb connection on the CO₂ regulator. (See Illustration B, on page 6)
2. Insert the special washer (provided with the kit) into the regulator to cylinder attachment nut. (See Illustration A, on page 6)
3. Attach the CO₂ regulator to the CO₂ cylinder by screwing the regulator nut onto the cylinder valve and tightening with an adjustable wrench.
4. Wrap the rubber strap that is attached to the interior of beer keg fridge unit around the CO₂ bottle to secure the bottle in place (as shown above).
5. Position the cylinder so that you would be able to read the numbers on the gauges and have easy access to shut-off valves.

DANGER!

CO₂ can be dangerous! CO₂ cylinders contain high-pressured gas, which can be hazardous if handled improperly. They must be handled with care.

TAPPING THE BEER KEG – INSTALLING KEG TAP (SINGLE-VALVE TYPE BARREL)

Follow these steps below to tap the beer keg.

1. Make sure the black pull handle of the tap is in the closed (up) position before installing it on the keg (Fig. 1 - below). Insert the keg coupler into the locking neck of the beer keg and turn clockwise $\frac{1}{4}$ to lock it into position (Fig. 2 - below). This means that it is secured to the keg.
2. When connecting the beer line, it is very important that the black rubber washer be installed inside the wing nut before connecting the beer line to the tap (See Illustration A below). Remove the black rubber protective cap located on top of tap and screw the Wing nut with the rubber washer. Tighten it firmly by hand. (Fig.2-below)

3. Attach the CO₂ line end of the tube to the hose connection on the tap. Next, secure the tube by using the remaining self-locking plastic snap-on clamp to ensure that there are no leaks. Secure the clamp tightly with pliers (Fig. 3 - below).
4. Make sure the beer tower faucet is in the closed (handle pointing straight back) position before connecting the tap to the keg. To secure the tank connection, pull the tapping handle out and push down until it locks into position. Listen for the "click" of the pull handle when it shifts into the final downward position (Fig. 4 - below). This will open the beer and CO₂ gas valves. The keg is now tapped.
5. Carefully tilt the keg and rest the edge on the keg floor support on the bottom of the interior cabinet. Slide the beer keg slowly, ensuring that it is properly located (Fig. 5 - below) and carefully close the door.
6. Your beer keg fridge comes with a 2.5 lb. CO₂ bottle, which should be able to dispense **four 15 gallon kegs of beer.**

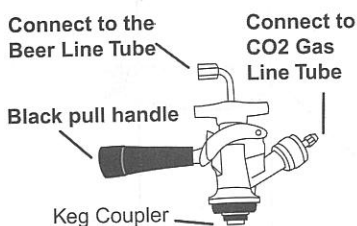

fig. 1



fig. 2



fig. 3

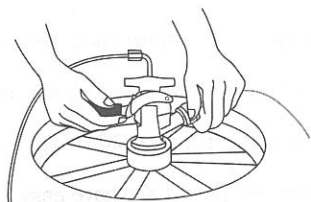

fig. 4

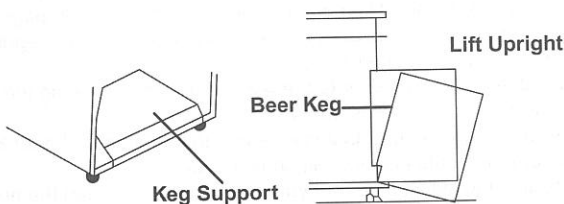

fig. 5

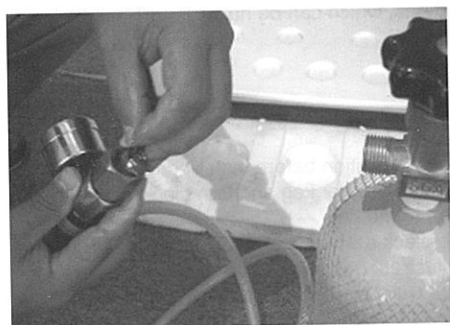

Illustration A
Black Rubber Washer Installed in Wing Nut

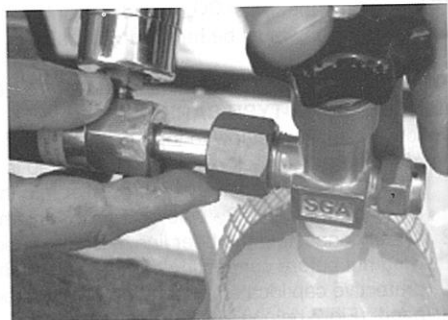

Illustration B
Then Attach to CO₂ Bottle Connector

OPERATING YOUR BEER KEG FRIDGE

Dispensing Beer

Follow the steps below to dispense beer.

1. Make sure that the beer keg fridge is plugged in properly to a 120V, 60Hz, 16Amps grounded AC power outlet.
2. place the drip tray under beer faucet to avoid messes from excess beer.
3. Open the beer faucet by pulling the tap to wards you to dispense the beer.
Note: If for any reason the beer does not come out of the tap, please refer to the "Tapping the beer Keg - Tap" section.
4. Increase the pressure if the beer runs too slowly.
5. Hold the glass steady at a 45° angle. When it is 2/3 full, straighten the glass. Proper foam should be a tight creamy head and the collar on an average glass should be 3/4" to 1" high, ideally.

Note: It is normal to see condensation from on the faucet. It is caused by the difference of temperature between the cold beer and the inside of the faucet when beer is fowing through the line.

CLEANING & MAINTENANCE

Flushing the tubes

Follow the steps below to clean the keg tap and hoses. (See Illustration right)

1. Turn off CO₂ completely before attempting to clean.
2. Remove the hose from the coupler and carefully twist the dispenser faucet off the top the beer keg fridge.
3. Ensure that the dispenser handle is in the down position before flushing the hose. If this is not set correctly, water cannot flow through. Hold the open end of the hose under running water for 3-5 minutes, while the beer dispenser faucet drains into the sink. This will clear any excess beer that is trapped inside, helping to prevent any bacteria or mold that could accumulate inside.
4. In order to clean and remove any excess beer that may leak into the unit space inside the door, remove the black rubber insulation and wipe with a wet towel as needed.

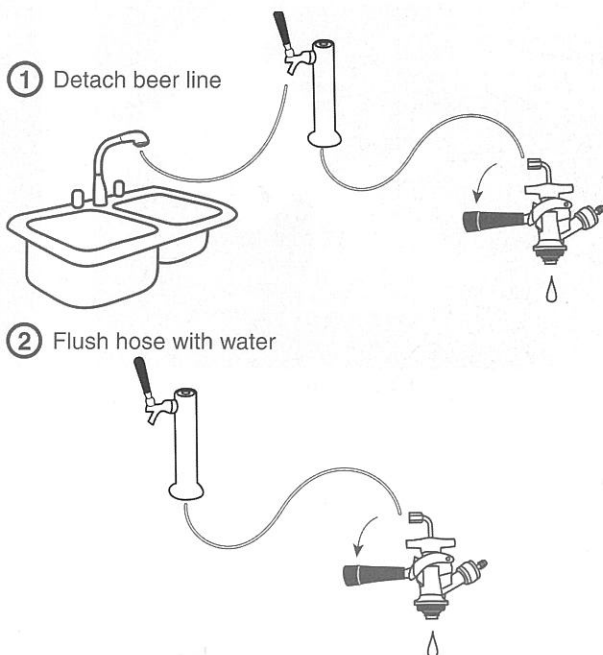

Storage & Care

Follow the guidelines below to care for your beer keg fridge when not in use.

- Please adjust the temperature control dial to MID or LOW in colder environments because this unit does not self-defrost and ice may build up inside the unit. The temperature control dial is located inside the cabinet of the beer keg fridge.
- Always rinse the beer line if you do not intend to use your beer keg fridge, inside the cut out area at the bottom, lower left.
- To avoid permanent damage to the unit, never use sharp object inside the beer keg fridge.

SPECIAL SAFETY INFORMATION

Important Safety Message for Draft Beer Dispensing

Your beer keg fridge system has two safety devices already provided in the CO₂ pressure line. The coupler for this beer keg fridge is compatible with the ¼ Pony Keg sized barrel and the ½ Barrel full size (US Kegs). While the beer keg fridge can hold both the 5 gallon Cornelius Keg and the 5 gallon D System Keg, should you decide to run either one of these 5 gallon kegs, you may need to obtain a alternate keg connector.

Safety devices should be installed in the following places:

- On or directly downstream from the CO₂ regulator.
- On the tapping device.
- In-line in the pressure system

Note: Locations A and B noted above are preferable. If possible, they should be built into the CO₂ regulator and tapping device so that they cannot be removed or by-passed.

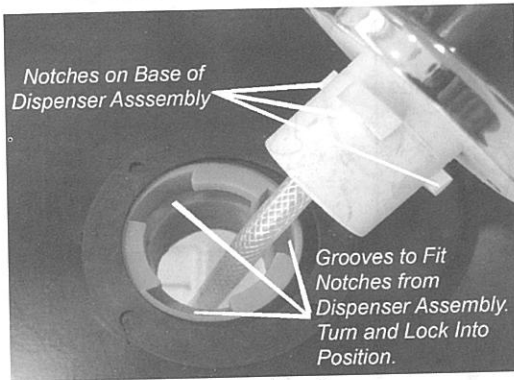

Illustration C

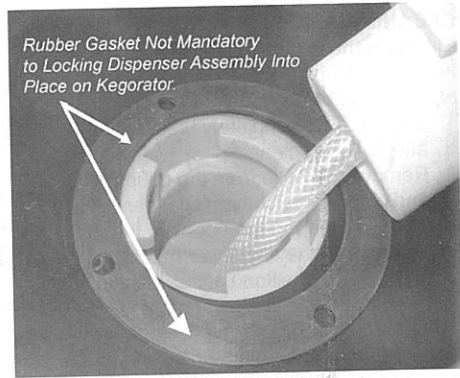
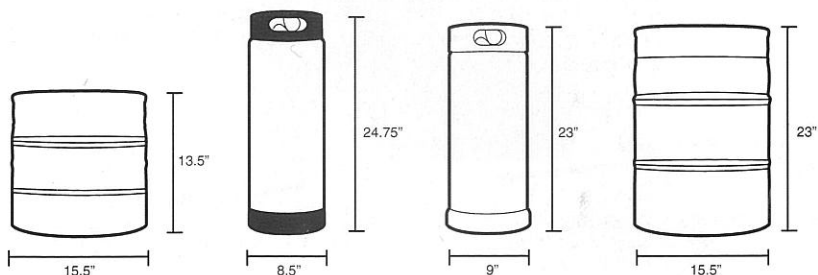

Illustration D

Compatible Keg Types

The KEGORATOR™ can hold one Full Size Keg, or one Pony Keg, or two 5-Gallon Kegs.



1/4 Barrel Pony Size

5 Gallon Cornelius Keg

5 Gallon D System

1/2 Barrel Full Size

Parts & Assembly

Read assembly instructions carefully to ensure that you understand all installation instructions before installing the KEGORATOR™. If after completing the process you are still unsure whether the KEGORATOR™ has been properly installed, we recommend that you contact a qualified installer.

Allow the KEGORATOR™ to stand in an upright position for about 8 hours before turning on the power. This is very important! Once the unit is laid on it's side, the Freon in the refrigeration unit is shifted. The Freon in the refrigeration unit needs to stabilize before the power is turned on.

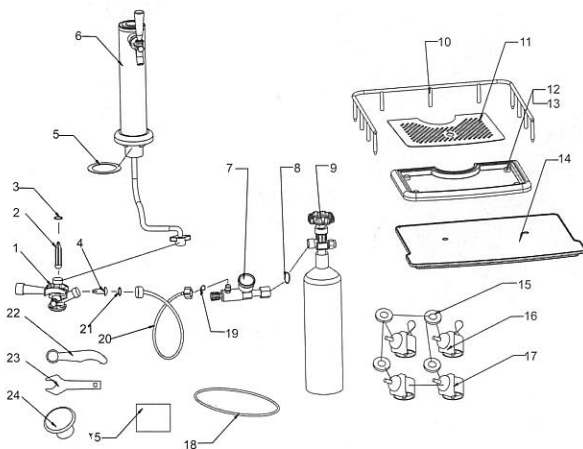

ACCESSORIES	QUANTITY
1. KEG COUPLER	1
2. BACK FLOW STOPPER	1
3. RUBBER WASHER	1
4. CO2 RUBBER DIRECTIONAL WASHER	1
5. BEER TOWER WASHER	1
6. BEER TOWER TAP-BEER HOSE ASSEMBLY	1
7. CO2 REGULATOR	1
8. HIGH PRESSURE WASHER	1
9. CO2 TANK VALVE	1
10. GUARD RAIL	1
11. DRIP PAN TOP	1
12. DRIP PAN	1
13. RUBBER FOOT	4
14. KEG BASE BOARD	1
15. METAL WASHER	4
16. KEGORATOR CASTERS BRAKE	2
17. KEGORATOR CASTERS	2
18. CO2 TANK STRAP	1
19. AIR HOSE WING NUT WASHER	1
20. AIR HOSE	1
21. AIR HOSE CONNECTOR WASHER	1
22. BEER TAP WRENCH	1
23. REGULATOR WRENCH	1
24. BEER TOWER HOLE COVER	1
25. EXTRA WASHERS (3 4, 8 19 21)	1

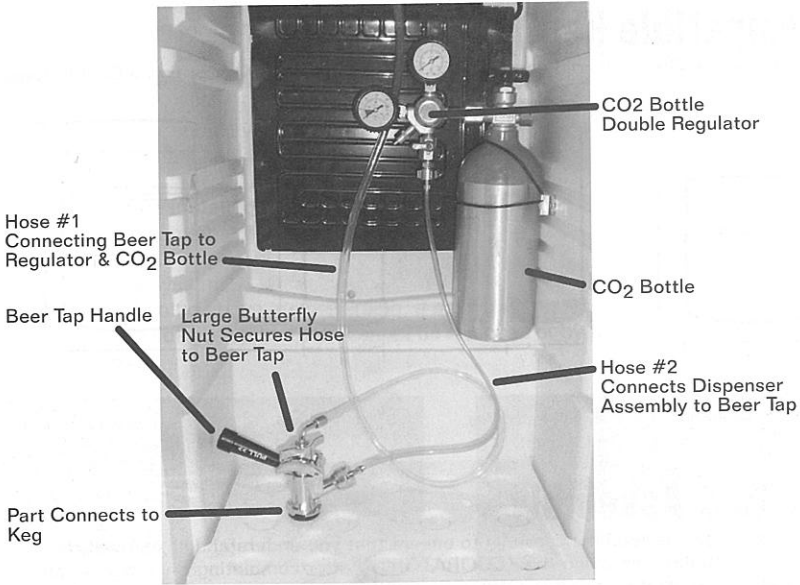

Regulator

The regulator works the Co2 Tank Valve and measures PSI (pounds per square inch), as well as the volume of the Co2 gas in the Cylinder.

Output Pressure Gauge (0-60 PSI) for measuring PSI of CO₂ outflow from Tank to Keg.

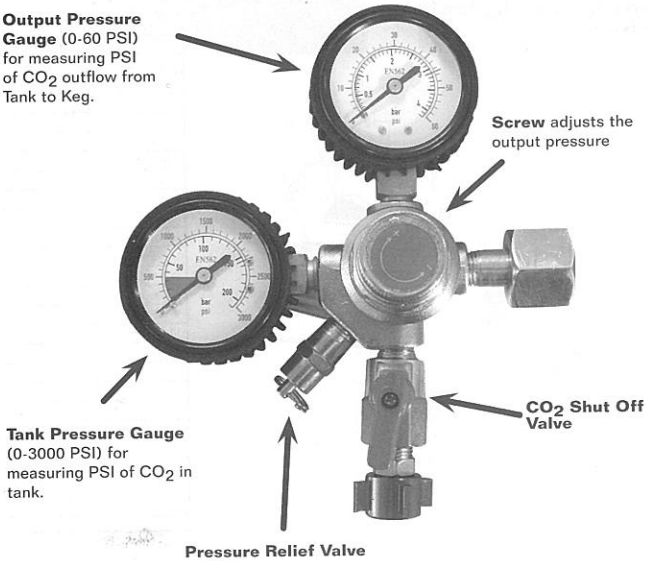

Installation

Follow these steps to safely install the CO₂ regulator and CO₂ cylinder. You must read and understand the following procedures for the CO₂ cylinders before installation.

NOTE: If all your rubber washers & O-rings are not pre-installed, please refer to your parts list (pg. 6).

NOTE: Your CO₂ cylinder has DOT (USA Department of Transportation) approval, however the cylinder has been shipped empty to avoid any possible accidents during transportation. When you purchase the first keg of beer, you must also have your CO₂ cylinder filled at your local supplier. (see page 2, number 9, for suggested locations within your community)

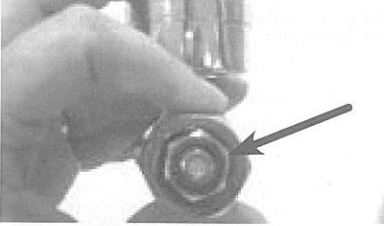

STEP 1
High pressure washer installed into CO₂ regulator (may already be installed)

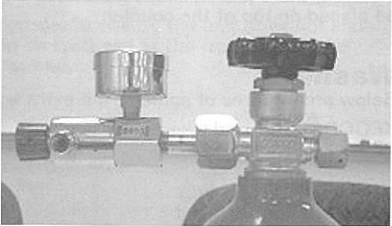

STEP 2
Attach regulator to CO₂ tank connector.

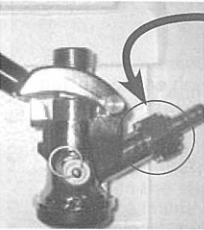

Some units may come with this attachment. It is not needed and should be removed from the coupler prior to **STEP 3**.



STEP 3
The CO₂ rubber directional washer goes into the coupler.

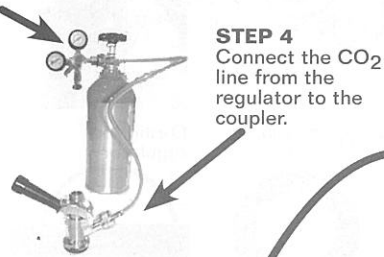

STEP 4
Connect the CO₂ line from the regulator to the coupler.

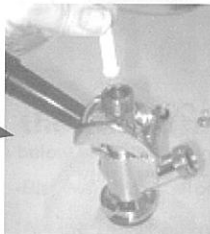

STEP 5
Put one of the backflow stoppers in the coupler (the torpedo goes in with rounded side down).

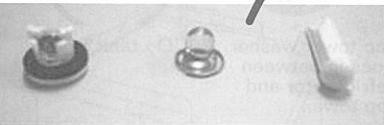

There are three different possible backflow stoppers.

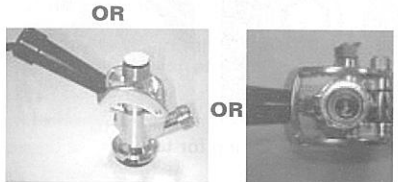

Installation, cont.



STEP 6
After the backflow stopper has been inserted, there is a washer that should be placed on top of the coupler.



STEP 7
After the tap tower has been placed on the refrigerator and the hose line feeds through the bottom, attach the wing nut to the coupler.

Washers

Below are pictures of some of the extra washers that are included with the KEGORATOR™ and where they belong.

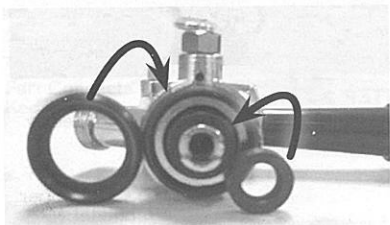

O-rings on the CO₂ line



CO₂ line to regulator



CO₂ line to coupler



O-ring for coupler



O-ring for regulator



O-ring for tap



Tap tower washer goes in between refrigerator and tap tower.



CO₂ tank band

1. Empty the inside of the cabinet completely and lay the KEGORATOR™ down on it's side. We recommend that you place a piece of cardboard or cloth underneath the cabinet to prevent dents or scratches.
2. Insert the casters into the holes on the bottom corners of the cabinet. Tighten each caster by turning the nut clockwise with a wrench (not provided in the kit).
3. Once all four casters have been tightened, stand the cabinet in its upright position.

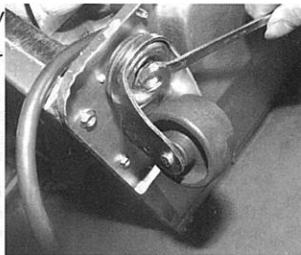

Note: Two of the casters include locking mechanisms to ensure the unit does not slide on hard floors. These two locking casters should be fastened at the front end of the unit, with the unlocked casters fastened on the rear end.

Installing the Beer Tap

Follow the steps below to install the beer tap.

1. Remove the cabinet plug located on the work top. Firmly grasp the cabinet plug, twist and pull upward.

Note: Keep this plug in a safe place -- it will be required when using the KEGORATOR™ as a refrigerator without a beer keg in use.

2. There are notches on the bottom of the draft arm assembly that line up with grooves inside the opening in the top of the KEGORATOR™. Align the draft arm with the opening in the top of the unit, then place inside and twist until secure. No screws are necessary, it locks into place simply. The thin black gasket is not mandatory for assembly.

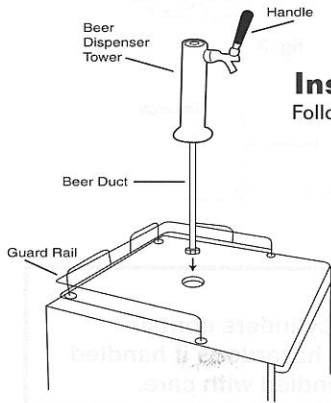
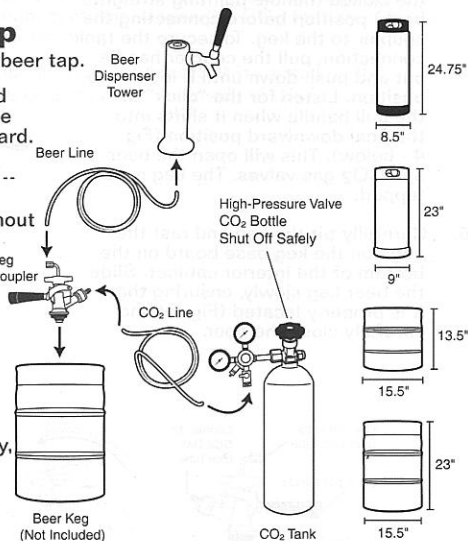

Installing the Guardrail

Follow the steps below to install the guardrail.

1. Place the guardrail on top of the cabinet.
2. Align all holes of the guardrail with the holes of the cabinet.
3. Secure the guardrail to the cabinet by placing inside corresponding rubber holes.

Tapping the Beer Keg (Single-Valve Type Barrel)

Follow these steps below to tap the beer keg.

1. Make sure the black pull handle of the coupler is in the closed (up) position before installing it on the keg (Fig. 1 - below). Insert the keg coupler into the locking neck of the beer keg and turn clockwise until it locks into position (Fig. 2 - below). This means that it is secured to the keg.
2. When connecting the beer line to the top of the coupler, it is very important that the wingnut tightens completely. This must be completed prior to inserting the backflow stopper into the coupler.
3. Before attaching the CO₂ line, be sure to insert the rubber directional washer into the side of the coupler. Attach the CO₂ line (see step 3 on pg. 5) and hand-tighten firmly. Secure the tank with CO₂ tank strap.
4. Make sure the beer tower faucet is in the closed (handle pointing straight back) position before connecting the coupler to the keg. To secure the connection, pull the coupler handle out and push down until it locks into position. Listen for the "click" of the pull handle when it shifts into the final downward position (Fig. 4 - below). This will open the beer and CO₂ gas valves. The keg is now tapped.
5. Carefully tilt the keg and rest the edge on the keg base board on the bottom of the interior cabinet. Slide the beer keg slowly, ensuring that it is properly located (Fig. 5) and carefully close the door.

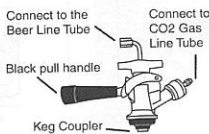
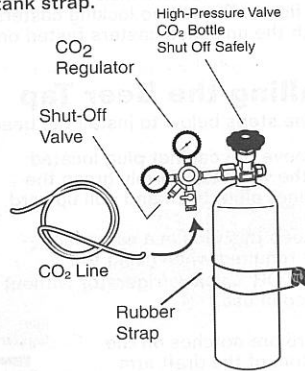

fig. 1



fig. 2



fig. 3



fig. 4

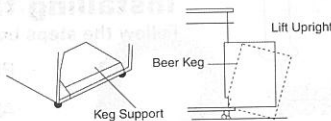

fig. 5

DANGER!
CO₂ can be dangerous! CO₂ cylinders contain high-pressured gas, which can be hazardous if handled improperly. They must be handled with care.

Follow the steps below to dispense beer.

1. Make sure that the KEGORATOR™ is plugged in properly to a 120V, 60Hz, 15 Amps grounded AC outlet.
2. Place the drip tray under the beer faucet to avoid messes from excess beer.
3. Open the beer faucet by pulling the tap towards you to dispense the beer.

NOTE: If for any reason the beer does not come out of the tap, please refer to the **Tapping the Beer Keg** section.

4. Increase the pressure if the beer runs too slowly.
5. Hold the glass steady at a 45° angle. When it is $\frac{2}{3}$ full, straighten the glass. Proper foam should be a tight creamy head and the collar on an average glass should be $\frac{3}{4}$ " to 1" high, ideally.

NOTE: Only open the CO₂ tank $\frac{1}{4}$ turn to begin with and then use the regulator to adjust to desired pour. If it is not enough, continue to open the CO₂ tank by $\frac{1}{4}$ turn and use regulator until desired setting is reached.

NOTE: It is normal to see condensation form on the faucet. It is caused by the difference in temperature between the cold beer and the inside of the faucet when beer is flowing through the line.

TECHNICAL DATA

Power Supply: 115V/60HZ

Rated Current: 1.9A

Capacity: 170 L/6.0 CUFT



INSTRUCTIONS ON ENVIRONMENT PROTECTION

Do not dispose of this product in the usual household garbage at the end of its life cycle; hand it over at a collection point for the recycling of electrical and electronic appliances.

The materials are recyclable. By recycling, you are making an important contribution to protect our environment.



POLARIZED ELECTRICAL POWER PLUG

This appliance is equipped with polarized plug; this type of plug has one blade wider than the other. The plug will fit into an electrical outlet only one way. This is a safety feature intended to reduce the risk of electrical shock. If you are unable to insert the plug into the outlet, try reversing the plug. If the plug should still fail to fit, contact a qualified electrician to replace the obsolete outlet. Do not attempt to defeat the safety purpose of the polarized plug by modifying the plug in any way.

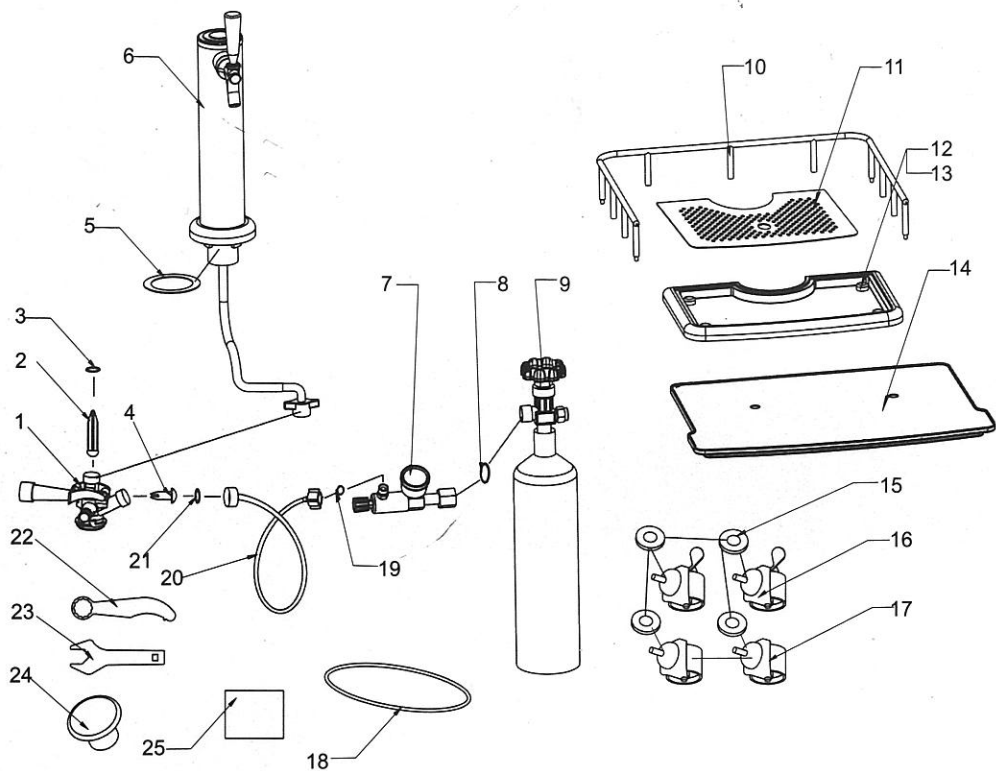

ACCESSORIES	QUANTITY	ACCESSORIES	QUANTITY
1. KEG COUPLER	1	14.KEG BASE BOARD	1
2.BACK FLOW STOPPER	1	15. METAL WASHER	4
3. RUBBER WASHER	1	16.KEGORATOR CASTERS BRAKE	2
4.CO2 RUBBER DIRECTIONAL WASHER	1	17.KEGORATOR CASTERS	2
5.BEER TOWER WASHER	1	18.CO2 TANK STRAP	1
6.BEER TOWER TAP/BEER HOSE ASSEMBLY	1	19.AIR HOSE WING NUT WASHER	1
7.CO2 REGULATOR	1	20. AIR HOSE	1
8.HIGH PRESSURE WASHER	1	21.AIR HOSE CONNECTOR WASHER	1
9.CO2 TANK VALVE	1	22.BEER TAP WRENCH	1
10.GUARD RAIL	1	23.REGULATOR WRENCH	1
11.DRIP PAN TOP	1	24.BEER TOWER HOLE COVER	1
12.DRIP PAN	1	25.EXTRA WASHERS (3、4、8、19、21)	1
13.RUBBER FOOT	4		