



Black

White

BI95

ADA SERIES

FEATURES

PERFORMANCE

- Daily ice rate of up to 23 lbs of crescent ice
- Stores up to 12 lbs of ice
- Uses less than 3 gallons of water to produce 25 lbs of ice, conserving both energy and water
- Uses less energy than a 75 watt light bulb
- Perfect size crescent ice cubes (1/2"W x 3/4"H x 2-1/2"L)
- Mechanical control monitors ice making operation to ensure maximum daily ice production
- Manual defrost

INTERIOR / EXTERIOR

- 24-3/4" height meets ADA height requirement
- No drain required, easy and inexpensive to install and requires only a 1/4" outside diameter water line
- Field reversible door
- Vinyl clad textured cabinet is more resistant to scratching, peeling and flaking

INTEGRATION

- Unit can be built-in or freestanding providing a custom aesthetic
- Will accept a 1/4" insert panel to match with surrounding decor
- Must add 1-1/2" to depth for water line connection
- Allow 1/4" width overall for proper installation
- No additional clearance around sides, top of unit is needed for ventilation
- Do not obstruct front grille



No ice shortages here. Produces up to 23 pounds of crescent ice (1/2" W x 3/4" H 2-1/2" L) per day. No drain required.

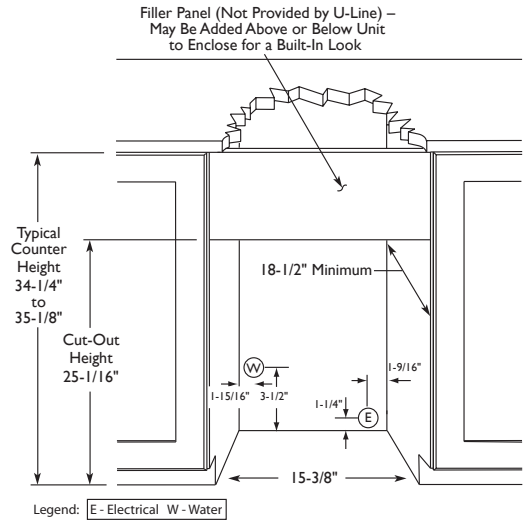
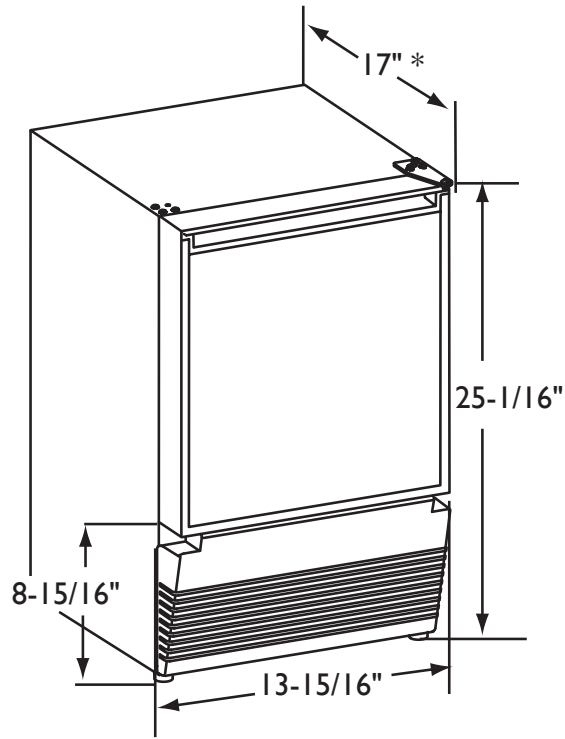

BI95B Black Model and BI95WH White Model

* Add 1-1/2" for water line clearance

DIMENSIONS AND SPECIFICATIONS

OVERALL DIMENSIONS

Height	25-1/16" (63.6)
Width	13-15/16" (35.4)
Depth	17" (43.2)

Shipping weight:

Black and white models 66 lbs (30 kg)

Running amps	2.5
Maximum start-up amps	18.0
Amps pertain to voltage rating	110/115 volt, 60 Hz
Approximate daily ice production	Up to 23 lbs
Ice storage	Up to 12 lbs

Optional in 220/230 voltage, 50/60 Hz
 On the 220/230 volt models, amps are decreased by approximately 50 percent.

BI95	
Black	ULN-BI95B-00
White	ULN-BI95WH-00

Please visit www.u-line.com for installation guide.

All specifications are subject to change without notice.

