

*Charmglow*  
America's Original Gas Grill

## OWNER'S MANUAL

Assembly and Maintenance Instructions for all Charmglow Post Models



**CHARMGLOW PATIO PRO**

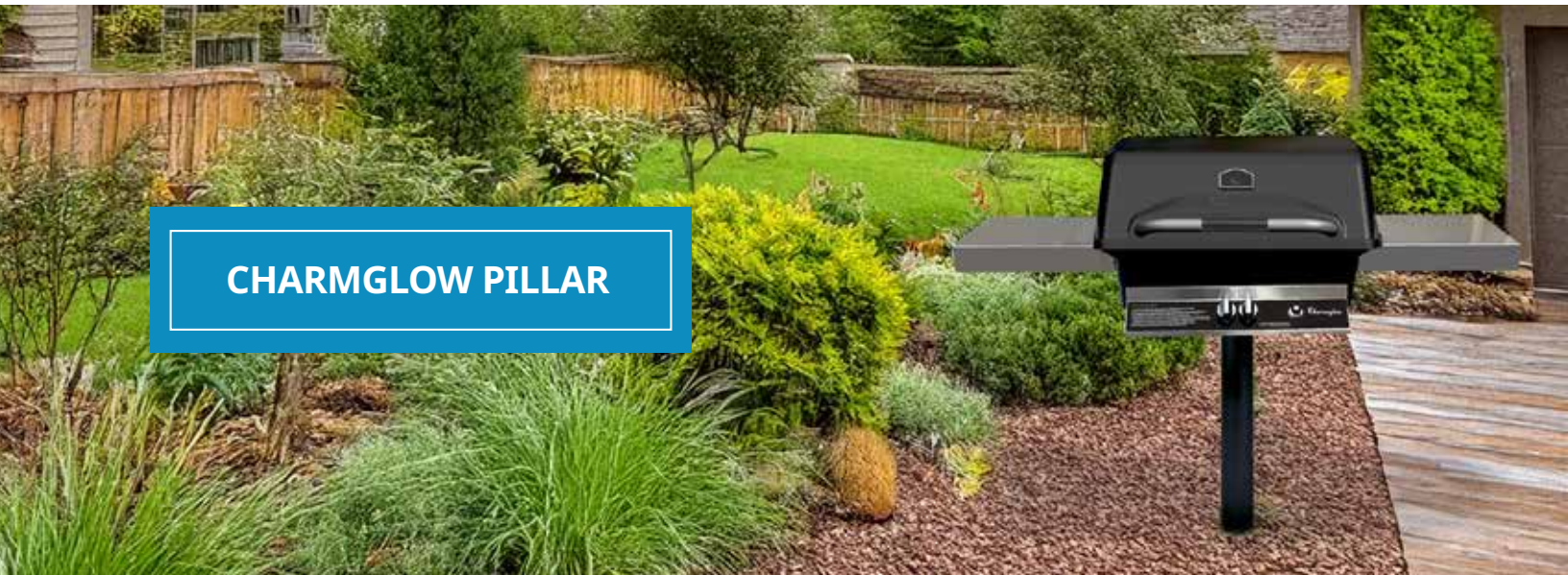

**CHARMGLOW PILLAR**

**READ ALL INSTRUCTIONS CAREFULLY AND MAKE SURE YOUR GAS GRILL IS PROPERLY INSTALLED AND ASSEMBLED BEFORE OPERATING. FAILURE TO FOLLOW THESE INSTRUCTIONS MAY RESULT IN SERIOUS BODILY INJURY AND/OR PROPERTY DAMAGE.**

**RETAIN THESE INSTRUCTIONS FOR FUTURE REFERENCE.**

# IMPORTANT SAFETY WARNINGS

**Failure to follow the Dangers, Warnings and Cautions contained in this Owner's Manual may result in serious bodily injury or death, or in a fire or explosion causing damage to property.**

## CALIFORNIA PROPOSITION 65 WARNING:

Chemicals known to the State of California to cause cancer, birth defects or other reproductive harm are found in and/or created by the combustion of natural gas, propane, butane and other fuels. Always operate this unit as described in the owner's manual and in well ventilated areas.

## WARNING: FOR YOUR SAFETY:

- Do not store a spare or disconnected liquid propane cylinder under or near the grill.
- Improper assembly may be dangerous. Please carefully follow the assembly instructions in this manual.
- After a period of storage, and/or non-use, the grill should be checked for gas leaks and burner obstructions before use. See instructions in this manual for correct procedures.
- Do not operate the grill if there is a gas leak present.
- Do not use a flame to check for gas leaks.
- Combustible materials should never be within 18 inches of the bottom, back or sides of your grill.
- Do not put a grill cover or anything flammable on, or in the storage area under the grill.
- Children should never use your grill. Accessible parts of the grill may be very hot. Keep young children away while it is in use.
- Exercise reasonable care when operating your grill. It will be hot during cooking or cleaning and should never be left unattended, or moved while in operation.
- Should the burners go out while in operation, turn all gas valves off. Open lid and wait five minutes before attempting to relight, using the lighting instructions.
- Do not use charcoal or lava rock in your grill.
- Never lean over open grill or place hands or fingers on the front edge of cooking box.
- Do not enlarge the valve orifices or burner ports when cleaning the valves or burners.
- The grill should be thoroughly cleaned on a regular basis.
- Liquid propane gas is not natural gas. The conversion or attempted use of natural gas in a liquid propane unit or liquid propane gas in a natural gas unit is dangerous and will void your warranty.
- Do not attempt to disconnect any gas fitting while your grill is in operation.
- Use heat-resistant grill mitts or gloves when operating grill.

## LIQUID PROPANE GAS UNIT ONLY:

- Use the regulator that is supplied with your grill.
- Do not attempt to disconnect the gas regulator or any gas fitting while your grill is in operation.
- A dented or rusty propane cylinder may be hazardous and should be checked by your local liquid propane supplier. Do not use a liquid propane cylinder with a damaged valve.
- Although your liquid propane cylinder may appear to be empty, gas may still be present, and the propane cylinder should be transported and stored accordingly.
- If you see, smell or hear the hiss of escaping gas from the liquid propane cylinder:
  1. Move away from the liquid propane cylinder.
  2. Do not attempt to correct the problem yourself.
  3. Call your fire department.

# TABLE OF CONTENTS

<b>Safety</b> .....	2
<b>General Instructions</b> .....	4-5
<b>Patio Pro Assembly</b>	
Parts & Hardware .....	6-7
Mounting.....	8
Connecting the Gas Line .....	9
Securing the Patio Base.....	10
<b>Pillar Assembly</b>	
Parts & Hardware .....	11-12
Assemble the In-Ground Post .....	13
In-Ground Mounting Preparation .....	14
Running the Gas Supply Line .....	14
Connecting the Gas Line .....	14
<b>Casting Assembly</b>	
Attach the Bottom Casting to Post.....	16
Install the Control Panel .....	17-18
Install the Side Shelves .....	19-20
Install the Top Casting .....	20
Install the Heat Plate.....	21
Install the Cooking Grids.....	21
Install the Warming Rack .....	21
Install the Handle.....	22
Install the Thermometer .....	23
<b>Gas Connections</b> .....	23
<b>Leak Testing</b> .....	24
<b>Getting to Know Your Grill</b> .....	25-26
<b>Troubleshooting</b> .....	27
<b>Grilling Techniques</b> .....	28
<b>Grilling Accessories</b> .....	29
<b>Maintenance</b>	
Annual Maintenance .....	30
General Maintenance .....	31-35
<b>Warranty</b> .....	36

Should you ever have any questions about the use or care of your Charmglow Gas Grill, we are here to help. Contact one of our friendly and helpful customer service representatives at:

**1.847.395.6556 | 1.888.647.4745 or [customerservice@charmglowgrill.com](mailto:customerservice@charmglowgrill.com)**



***Please have this information available when contacting Charmglow Customer Service***

**Model Number**

- CHRM40MPB (Patio Pro)
- CHRM40MPP (Pillar)

**Fuel Type**

- Natural Gas
- Liquid Propane (LP)

**How to find your model number/serial number**  
The model number tag is located on the left end cap of the control panel.

## GENERAL INSTRUCTIONS

**This installation guide provides you with easy to follow illustrations and instructions to assemble your Charmglow Gas Grill.**

**Before you start assembling and using your Charmglow Gas Grill we recommend that you read through all precautions, safe guards and instructions to avoid any personal injury or property damage.**

Check Local Codes. Contact your local LP dealer or Natural Gas company for recommended installation procedures and regulations. If there are no local codes, installation must conform to the latest National Fuel Gas Code: ANSI Z 223.1. For Canada, installation must comply with local codes and/or Standard CAN/CGA-B-149-1 for natural gas installation and CAN/CGA- B-149-2 for pro-pane installation.

**For LP Gas Models** the supplied Regulator must be used. Any replacement pressure regulator or hose assembly must meet or exceed the specifications of Charmglow. Refer to the parts list and contact the dealer where your grill was purchased. Use only Worthington, Manchester, or Wolfdale brand cylinders.

**For Natural Gas Models** the grill is designed to operate at a pressure of 7" water column (W.C.) (1.75 kPa). Check your gas utility for local pressure. Pressures other than approximately 7" W.C. could affect the performance of your grill.

## ASSEMBLY INSTRUCTIONS











**Your Charmglow Gas Grill arrives partially assembled, with essential internal components—such as the burner, venturis, ignitor collector box, and regulator—already installed at the factory.** To complete the setup, assemble the remaining external parts and accessories.

**The process is divided into 16 clearly outlined steps.** Each step provides detailed guidance, including the specific hardware required and any tools you'll need, so you can follow along with confidence and ease.

## STORAGE

**To ensure safe operation and storage of your gas grill, please follow these essential safety precautions:**

- Always turn the gas OFF at the LP cylinder (or at the shut-off valve for natural gas) when the Charmglow Gas Grill is not in use.
- Do not store spare LP cylinders underneath the grill.
- Store disconnected LP cylinders outdoors in a well-ventilated area—never in a shed, garage, building, or any enclosed space.
- When the cylinder is not in use, place the dust cap on the valve outlet. Only use the cap that comes with the cylinder valve—using any other type may cause propane to leak.

-  Do not install your Charmglow Gas Grill in or on recreational vehicles and/or boats.
-  Never use your Charmglow Gas Grill near combustible surfaces, including roof overhangs, roofs, vinyl siding and window shutters.
-  Use this grill outdoors in a well-ventilated area.
-  Do not use your Charmglow Gas Grill in a shed, garage, building, breezeway or any other confined area.
-  Do not use any kind of combustible material on or near the top, bottom, back or sides of the grill. Maintain at least an 18 inch clearance.
-  Leak test all gas supply line connections.
-  Do not let children operate a gas grill.
-  Keep the area around the grill clear of combustible vapors or liquids such as gasoline.
-  When operating the grill do not leave unattended. Keep children and pets away.
-  Keep fuel supply hose and electrical supply cord away from any heated surface.

### SAFETY!

#### **YOUR GRILL IS DESIGNED FOR OUTDOOR USE ONLY.**

- **It should not be used in an enclosed area** such as a shed or garage because combustion uses available oxygen and discharges carbon mon-oxide.
- **The grill must be located no closer than 18" from any combustible surface behind or to the sides.** Grill should not be located under overhead unprotected combustible surfaces.
- **Keep the area around the grill clear** of combustible materials, flammable vapors or liquids such as gasoline.
- **Do not obstruct the flow** of combustion and ventilation air.

# CHARMGLOW PATIO PRO ASSEMBLY INSTRUCTIONS

## BOXES/BAGS:

You should have the following boxes/bags containing the different parts and hardware needed to assemble your grill. *Contact your dealer if any parts are missing.*



**BOTTOM CASTING**



**TOP CASTING**



**OWNER'S MANUAL BAG**

*Includes:*  
 • Owner's Manual  
 • Temperature Gauge



**COOKING GRIDS**



**HEAT PLATE**



**WARMING RACK**



**NATURAL GAS  
CONTROL PANEL**

**OR**



**LP GAS  
CONTROL PANEL**



**PATIO PRO BASE**  
*Includes:*  
 • NuStone Patio Base,  
 • 2 Ft. Aluminum Post  
 • GGCTSS (NG Models)

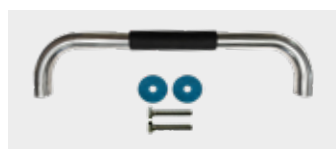

**HANDLE**  
*Includes hardware*



**GGGC**  
*Grease Cup*



**PATIO PRO HARDWARE PACK**  
*See page 7 for content details*

**PRE-PACKAGED PARTS AND FASTENERS**



**Patio Pro Hardware Pack**  
Used for post and base assembly



1/4-20 X 3/4" HEX BOLT  
(QTY: 7)



1/4-20 KEP NUT  
(QTY: 7)



1/4" FLAT WASHERS  
(QTY: 7)



GGGCH  
STAINLESS STEEL GREASE CUP HOLDER  
(QTY: 1)



GGLPP1  
STAINLESS STEEL COTTER PIN  
(QTY: 2)



GGLPP  
STAINLESS STEEL LID PIVOT PIN  
(QTY: 2)



HOSE CLIP  
(QTY: 1)



8/32 X 1/4 SELF TAPPING SCREW  
(QTY: 1)

**Additional Items Needed For Patio Base Installation**  
(Not Included)



3/8" FLARE COUPLING



LAG BOLTS (4)

Use appropriate  
Lag Bolts for  
your application



FLAT WASHERS (4)

**TOOLS LIST:**



SLOTTED/FLAT HEAD  
SCREW DRIVER



3/4" COMBINATION  
WRENCH



7/16" COMBINATION  
WRENCH



7/16"  
SOCKET WRENCH



ADJUSTABLE  
WRENCH

## STEP 1 PATIO PRO MOUNTING ASSEMBLY

### PARTS INCLUDED:



PATIO BASE (1)



ALUMINUM  
GRILL POST

### HARDWARE INCLUDED:

*Patio Pro Hardware Pack*



1/4-20 X 3/4"  
HEX BOLT  
(4)



1/4-20  
KEP NUTS  
(4)



1/4"  
FLAT WASHERS  
(4)

### TOOLS NEEDED



7/16"  
COMBINATION  
WRENCH



7/16"  
SOCKET  
WRENCH



**Please check to be sure that all parts are included before proceeding.** Contact your dealer if any parts are missing. Make sure to choose an assembly location with plenty of clearance.

**Make sure your main gas supply is turned off before starting assembly.**

- **Turn base on edge and insert the 2' post.** Align the notches in the post with the notches in the base.
  - ⚠️ **Close tolerances may require you to tap the top of the post to seat it completely into the base socket which will help to align the bolt slots**
- **Fasten post to base with four 1/4-20 x 3/4" Hex Bolts, Washers and Kep Nuts.** Place Washers as shown and tighten.

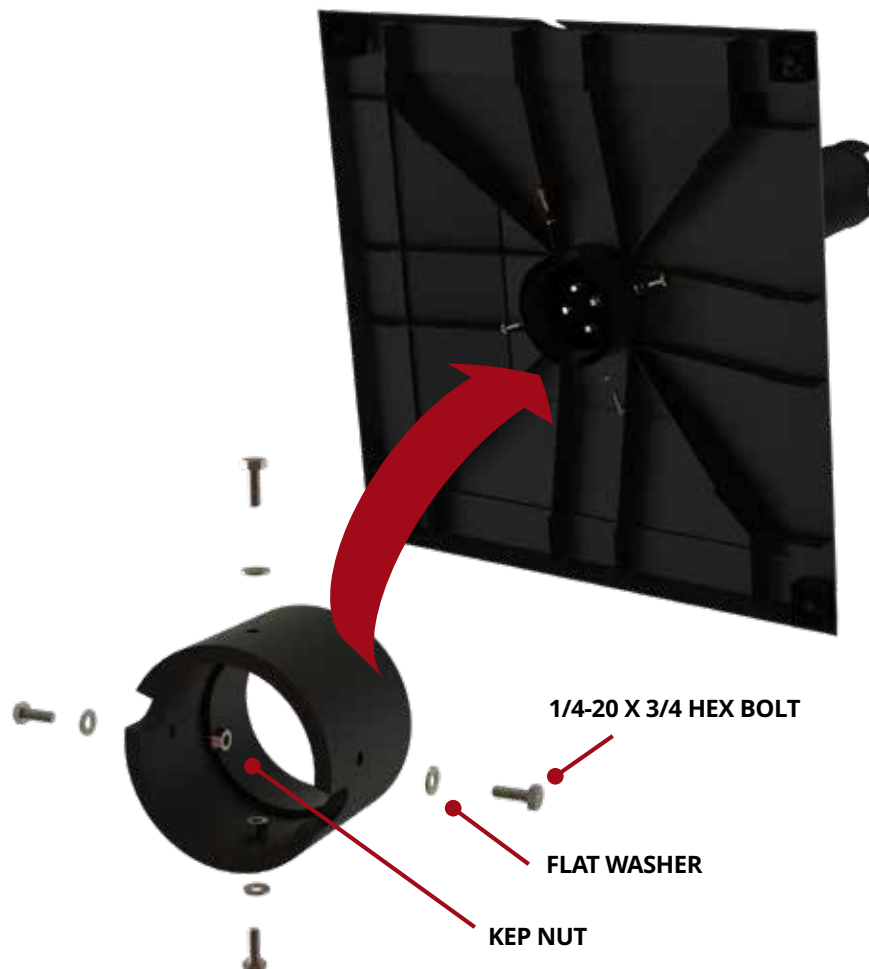

## STEP 2 CONNECTING GAS LINE

### PART INCLUDED:



28" FLEXIBLE STAINLESS STEEL TUBING

### HARDWARE INCLUDED:

Patio Pro Hardware Pack



TUBE CLIP  
(QTY. 1)



8-32 X 1/4  
SELF-TAPPING SCREW  
(QTY. 1)

### ADDITIONAL HARDWARE NEEDED:

Not supplied by Charmglow



3/8" FLARE COUPLING  
(not supplied by Charmglow)

### TOOLS NEEDED



3/4" COMBINATION WRENCH



ADJUSTABLE WRENCH



SLOTTED/FLAT HEAD  
SCREW DRIVER



**When installing a new gas line,** it is recommended that you contact a plumber, heating contractor or licensed gas fitter to install your new gas line to meet local building code. Be certain there are no combustible materials closer than 18" away (above, behind, left or right) from your assembled grill before permanently securing it as referenced in Step 3.

- **Mark the location of the four holes at the outside corners of the patio base and drill four holes.** After you have connected the gas supply line, the base will be fastened down with lag bolts (*not supplied by Charmglow*) that are appropriate to your concrete or wood application. The top post notch should be at the front of the grill and the rear access door will be in the back of the grill.
- **Run the gas supply line into the post from the bottom to reach the access door and bend it 90° to exit the base at either notch.** The patio base is notched on two sides to allow the gas line to exit either right or left.

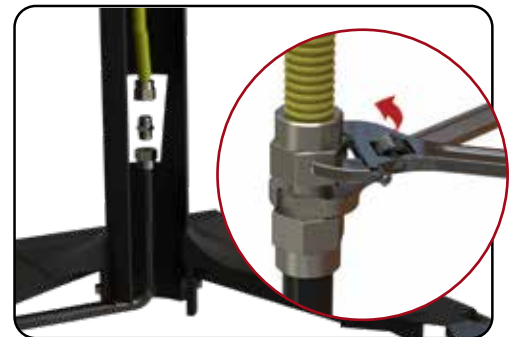

- ⚠️ **The gas supply line must be regulated** (*in the case of natural gas that means it should be connected after your gas meter and regulator*) and you must have an easily accessible main shut-off valve to your grill's gas supply. Grills are designed to operate on a pressure of 7" w.c. in. for Natural or 11" w.c. in for Propane at the grill valve connection.
- **Secure the gas line with the tube clip.** (*Option: On a raised deck if the gas supply line is to be run straight up into the post from below, use the tube clip to attach the gas line to the deck for support.*)
- **Attach the tube clip with the an 8-32 x 1/4 Self-Tapping Screw** on either the left or right side depending on direction of the gas supply line.

**At the post access window connect a 3/8" flare coupling** (*not supplied by Charmglow*) to the gas supply line then the flexible stainless-steel tubing (GGCTSS) using a 3/4" wrench. *The use of two wrenches is recommended—one wrench is used to hold fitting while the other is used to tighten.*

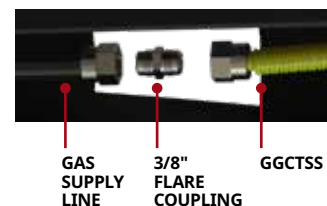

**WARNING:** A quick disconnect hose kit should not be used in place of the supplied GGCTSS flexible stainless steel tubing. This can result in fire and/or damage to your grill.

- ⚠️ **Tighten very securely as flare fittings are a metal-upon-metal surface seal and no additional gas sealant is needed.** Once your grill head is attached you should go back and check for any gas leaks with a soap and water solution before using your grill.

## STEP 3 SECURING THE PATIO BASE

### PART INCLUDED



ALUMINUM GRILL POST ACCESS DOOR

### HARDWARE NEEDED: *Not supplied by Charmglow*



*Use appropriate Lag Bolts for your application*

LAG BOLTS (4)  
*Not supplied by Charmglow*



FLAT WASHERS (4)  
*Not supplied by Charmglow*

### TOOL NEEDED:



RATCHET WRENCH WITH 7/16" SOCKET & EXTENSION

### After checking connections...

- Cover the access hole using the Access Cover.
- Anchor the Patio Base Plate into place. There are four corner holes. Based on the type of concrete or wood floor you have, fully secure the Patio Base with the appropriate lag bolts and washers for your application.

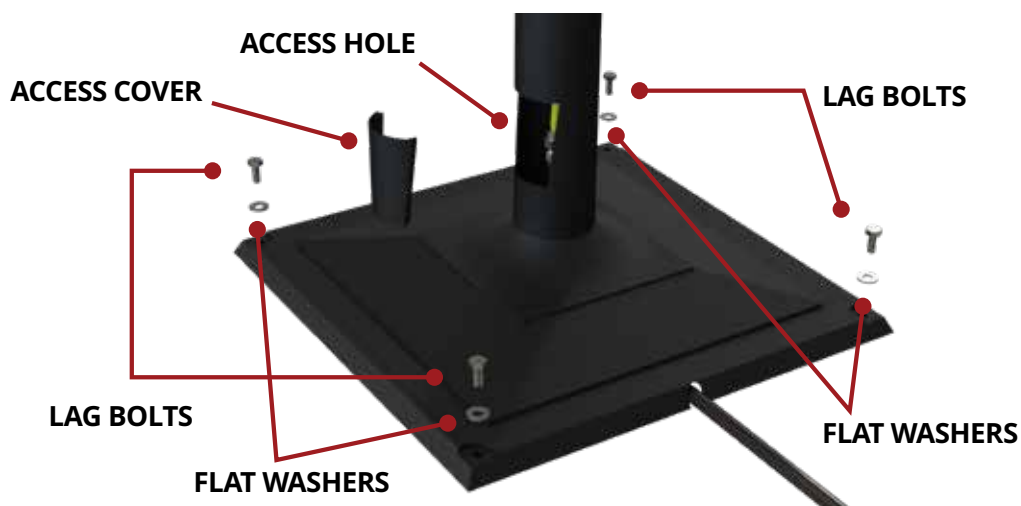

**You are now ready to attach the bottom casting to the Patio Pro post mounting.**

Instructions for attaching the bottom casting to the mounting can be found on page 16.

# CHARMGLOW PILLAR ASSEMBLY INSTRUCTIONS



FLAT WASHERS (4)



## BOXES/BAGS:

You should have the following boxes/bags containing the different parts and hardware needed to assemble your grill. Contact your dealer if any parts are missing.



BOTTOM CASTING



TOP CASTING



**OWNER'S MANUAL BAG**  
Includes:  
• Owner's Manual  
• Temperature Gauge



COOKING GRIDS



HEAT PLATE



WARMING RACK



NATURAL GAS  
CONTROL PANEL

OR



LP GAS  
CONTROL PANEL



**SHELVES (2), BRACKETS (4)  
& HARDWARE**  
Model CHRM40B comes  
with one shelf and  
two side brackets

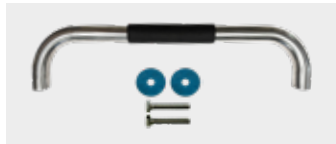

STAINLESS STEEL HANDLE



GGGC  
Grease Cup



GGCTSS  
28" Flexible Stainless Steel Tubing



**PILLAR HARDWARE PACK**  
See page 12 for content details



2-PIECE ALUMINUM POST

**PRE-PACKAGED PARTS AND FASTENERS**



**Pillar Hardware Pack**  
*Used for In-Ground assembly*



**1/4-20 X 1/2" STAINLESS STEEL  
BUTTON HEAD BOLTS**  
(QTY: 3)



**SERRATED  
LOCK WASHERS**  
(QTY: 3)



**FLAT WASHERS**  
(QTY: 3)



**ALLEN WRENCH**  
(QTY: 1)



**1/4-20 X 3/4" HEX BOLT**  
(QTY: 3)



**1/4-20 KEP NUT**  
(QTY: 3)



**GGGCH  
STAINLESS STEEL  
GREASE CUP HOLDER**  
(QTY: 1)



**GGLPP  
STAINLESS STEEL LID PIVOT PIN**  
(QTY: 2)



**GGLPP1  
STAINLESS STEEL COTTER PIN**  
(QTY: 2)

**Additional Items Needed For In-Ground Installation**  
*(Not Included)*



**3/8" FLARE COUPLING**



**CONCRETE**

**TOOLS LIST:**



**POST HOLE DIGGER**



**HAND LEVEL**



**ADJUSTABLE WRENCH**



**3/4" COMBINATION  
WRENCH**



**7/16" COMBINATION  
WRENCH**



**7/16" SOCKET  
WRENCH**

## STEP 1 ASSEMBLE 2-PIECE ALUMINUM IN-GROUND POST

### PARTS INCLUDED



POST  
Top Piece

POST  
Bottom Piece

2-PIECE ALUMINUM GRILL POST

### HARDWARE INCLUDED



1/4-20 X 1/2" STAINLESS STEEL  
BUTTON HEAD BOLTS (3)



SERRATED  
LOCK WASHERS  
(QTY: 3)



FLAT WASHERS  
(QTY: 3)

### TOOL INCLUDED:



ALLEN WRENCH  
(SUPPLIED)

1. Place both the top and bottom sections of the in-ground post on a flat surface.

2. Align the parts so that:

- The access holes on the top and bottom sections line up.
- The three threaded inserts on the bottom half match the corresponding pre-drilled holes on the top half.

3. Once the parts are aligned, slide the top half over the slotted, flanged end of the bottom half.

- The fit is snug, so be sure the holes are properly aligned before joining the pieces.
- If the holes don't line up, gently rotate the top half until they do, then push the halves fully together.



4. Once the two halves are fully joined, assemble, and install the hardware in the following order at each of the three pre-threaded connection points:

- > 1/4-20 x 1/2" stainless steel button head bolt
- > Serrated washer
- > Flat washer
- > Post

Button Head Bolt

Serrated Washer

Flat Washer

Make sure  
Top and  
Bottom  
Access  
Holes are  
aligned



5. Use the supplied Allen wrench to **tighten and secure all three bolts.**

6. **Double-check that all bolts are tight and the post sections are firmly locked together** before moving on with assembly.

TOP PIECE

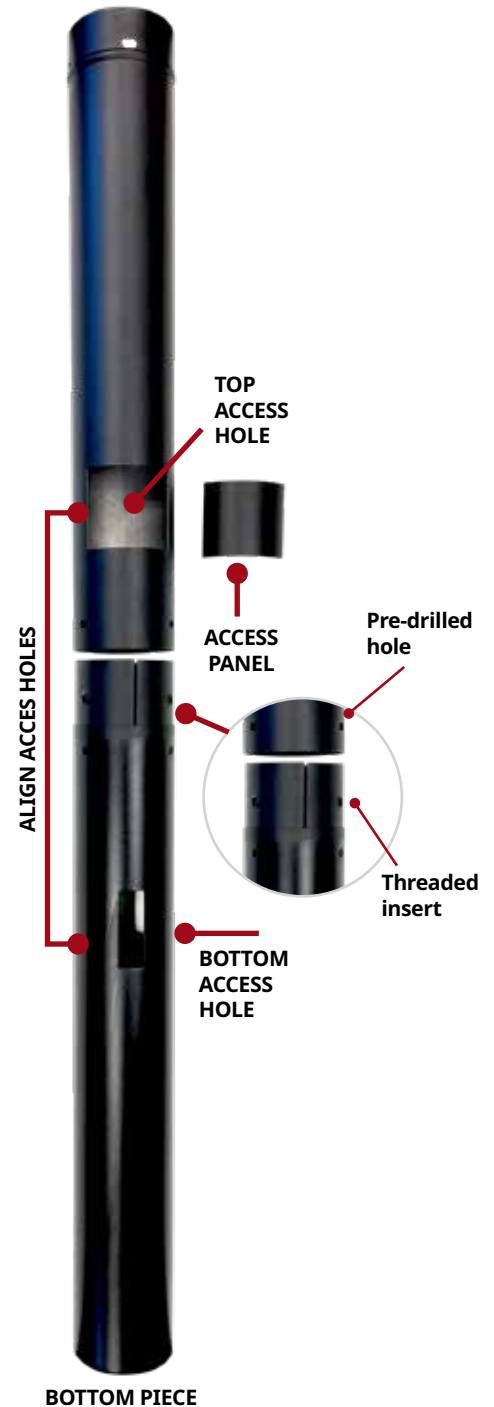

BOTTOM PIECE

## STEP 2 IN-GROUND MOUNTING PREPARATION



**A few days before installing, make sure to contact 811**, or visit your state's 811 website, to request that the approximate location of buried utilities be marked with paint or flags so that you don't unintentionally dig into an underground utility line.

- Once your area has been marked for utility lines, begin by digging a hole about 8 inches wide by 2 feet deep using a post hole digger.
- **⚠️ Locate the hole so that when the grill is mounted it has a clearance of at least 18" from any combustible object or surface; back, left and right.**
- Center the post in the hole and plumb it using a level. **Keep in mind that the gas line access hole is on the back of the post and the notch at the top is facing front.**
- Once you are sure that the post placement is correct, pour concrete mix (*per manufacturer's instructions*) into the hole and fill to a level just below the gas line access hole.
- Recheck post with level to ensure it is plumb and allow the cement to set per manufacturer's instructions.

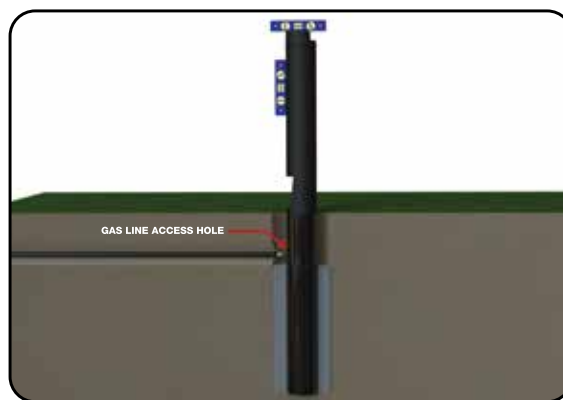
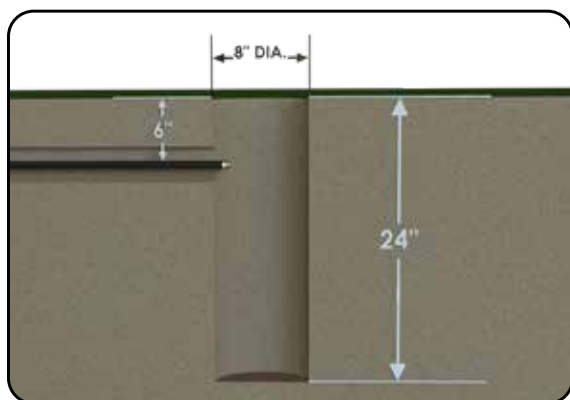

## STEP 3 RUNNING GAS SUPPLY LINE



**When installing a new gas line**, it is recommended that you contact a plumber, heating contractor or licensed gas fitter to install your new gas line to meet local building code.

- **Run the gas supply line into the access hole, which is located just above the cement, and make a 90° bend.** Your gas supply line should be long enough to reach all the way up to your access window that is located above ground level in the back of the post.
- **⚠️ The gas supply line must be regulated** (*in the case of natural gas that means it should be connected after your gas meter and regulator*) **and you must have an easily accessible main shut-off valve to your grill's gas supply.** Grills are designed to operate on a pressure of 7" w.c. in. for Natural or 11" w.c. in for Propane at the grill valve connection.



## STEP 4 CONNECTING GAS LINES

At the post access window connect a 3/8" flare coupling (not supplied by MHP) to the gas supply line then the yellow powder coated flexible stainless-steel tubing (GGCTSS) using a 3/4" wrench. The use of two wrenches is recommended—one wrench is used to hold fitting while the other is used to tighten.

- ⚠️ **Tighten very securely as flare fittings are a metal-upon-metal surface seal and no additional gas sealant is needed.** Once your grill head is attached you should go back and check for any gas leaks with a soap and water solution before using your grill.

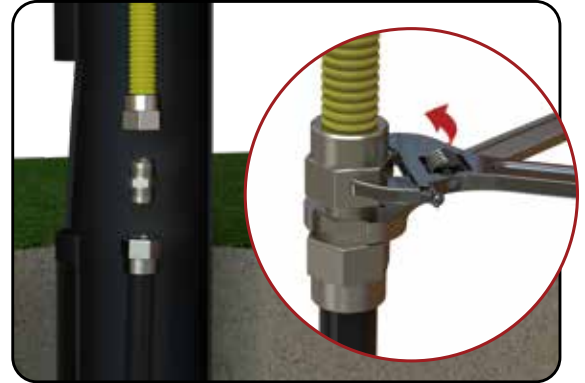

**After you have successfully assembled your grill—hook up your gas lines and check all connections.**

Ensure that your connections are secure and backfill the hole around your post, install your access hole cover and you're ready to attach the grill head to the post.

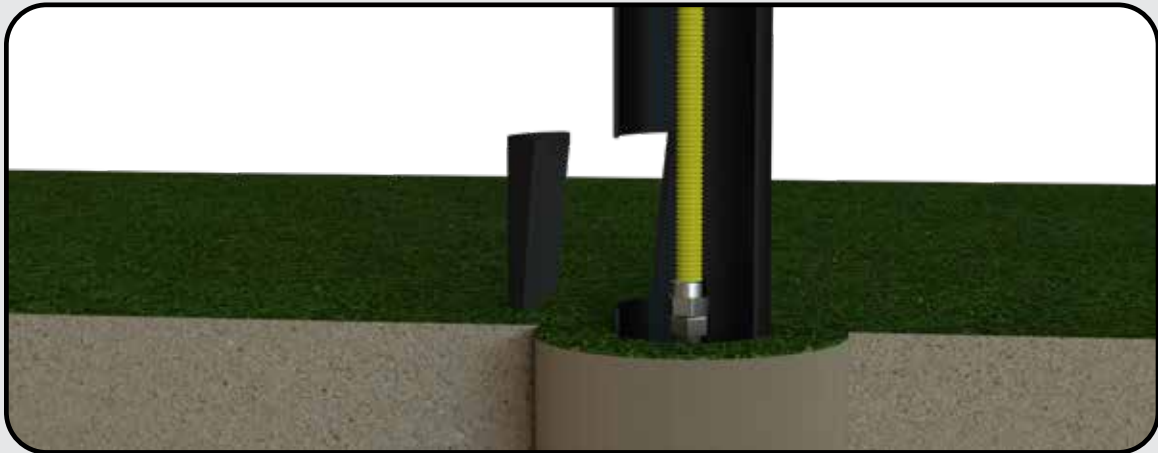

**You are now ready to attach the bottom casting to the Pillar post mounting.**

Instructions for attaching the bottom casting to the mounting can be found on page 16.

## CHARMGLOW PATIO PRO & PILLAR CASTING ASSEMBLY

### STEP 5 ATTACH THE CAST ALUMINUM BOTTOM CASTING TO POST

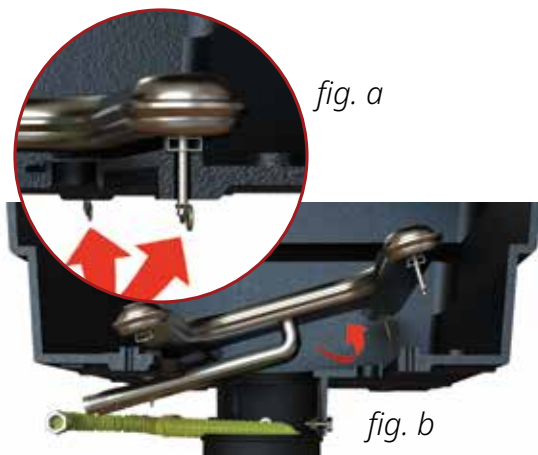

- Remove the grill burner by taking out the two small clips located under the bottom casting (fig. a)
- Pull the burner up and out of the the grill head (fig. b). This will allow access to hold the Kep nuts inside the post while attaching the bottom casting.

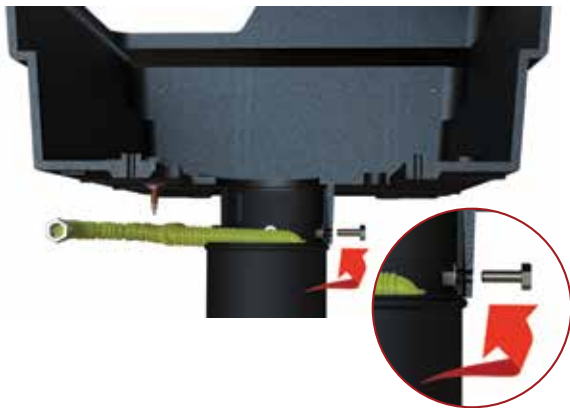

- Set the bottom casting carefully in place and align the holes
- Use the supplied 1/4-20 x 3/4" bolts and 1/4-20 Kep nuts to attach the casting to the post.
- Use a 7/16" socket wrench to hold the Kep nuts inside the post while tightening your bolt using a 7/16" combination wrench.



- Mount the grease cup holder to the rear flange hold with a 1/4-20 x 3/4" bolt and 1/4-20 Kep nut. The grease cup holder is supplied with the grill head.

## STEP 6 INSTALLING THE STAINLESS STEEL CONTROL PANEL

### Attaching the Control Panel Assembly to the Front of the Bottom Casting

- Attach the complete control panel assembly to the front of the bottom casting with two 1/4-20 Kep Nuts and hand tighten.
- Make sure the valve orifices on the control panel align with the burner venturi correctly and that the venturi tubes go over the valve orifices at least 1/4" to 3/8" (see *Valve Stem Engagement* below).
- Tighten all nuts using a 7/16" combination wrench.



### Connecting the Control Panel Support Brackets

Two support brackets are connected beneath the control panel to the bottom casting for added support.

- Attach the control panel to the support brackets by pushing up a 1/4 - 20 x 1/2" Phillips head bolt through the front hole of each support bracket and the lower lip of the control panel. Fasten brackets with a 1/4-20 Kep Nut.
- Push 1/4 - 20 x 1-1/4" Phillips head bolts down through the bottom casting from the inside and continue through the back hole on the support brackets. Secure the brackets with 1/4 - 20 Kep Nuts.
- Tighten all nuts using a screwdriver and a 7/16" combination wrench.

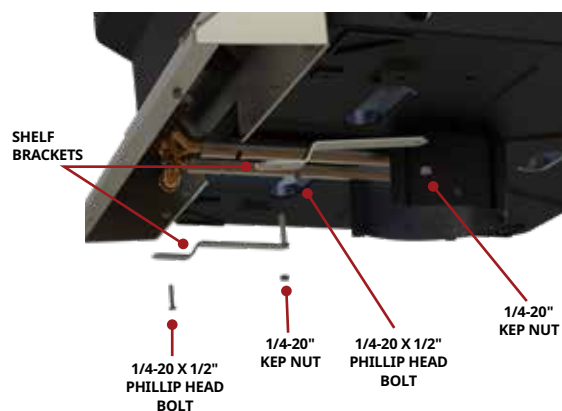

### Venturi Engagement

At the top end of each valve there is a tiny gas opening known as the orifice. Gas exits the orifice and enters a venturi where it mixes with air coming in from the side air shutter. The proper mixture of air and gas produces a clean blue flame at the burner.

- ⚠ **Make sure the valve orifice on the control panel aligns with the burner venturi tube correctly. The orifice should fit into the venturi tube 1/4" to 3/8".**



CORRECT



INCORRECT

## STEP 6 INSTALLING THE STAINLESS STEEL CONTROL PANEL, Continued

### Ignitor Wire Connection

Attach the wire from the ignitor module, located behind the control panel, to the porcelain insulator found on the underside of the bottom casting.

- ⚠ Be careful not to crack the delicate porcelain insulator



### Attach Knobs to Control Panel

Attach the two control knobs to the grill by pushing them down securely onto the valve stems.

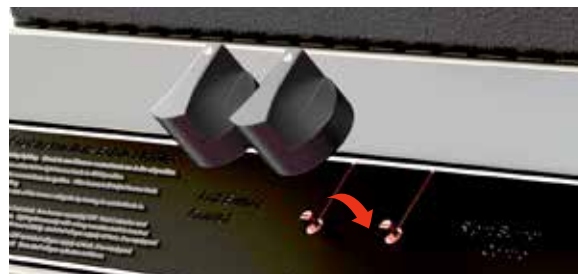

### Battery Installation

- Place the AAA battery "+" side down into the ignitor module.
- Install push button over the battery and turn clockwise to tighten in place.



### BENDING STAINLESS STEEL TUBING

**After you have successfully assembled your grill—hook up your flexible stainless steel tubing (GGCTSS) to your gas valve and check all connections.**

Do not make sharp bends when bending your flexible stainless-steel tubing to match the feed of your grill valve and position in the top notch of the post.



## STEP 7 INSTALL STAINLESS STEEL SIDE SHELVES

### PARTS INCLUDED:



SHELF (2)



SIDE BRACKETS (4)  
*Two left and two right brackets*

⚠ The CHRM40B Model only comes with one shelf and two side brackets (one left and one right bracket)

### HARDWARE INCLUDED:



1/4-20 X 1/2" PHILLIPS HEAD BOLTS (8)



1/4-20 KEP NUTS (8)



10-32 NYLOCK NUT (4)

### TOOLS NEEDED:



PHILLIPS SCREWDRIVER



7/16" COMBINATION WRENCH

3/8" COMBINATION WRENCH

### Remove Plastic Protective Sticker

Before installing the side shelf, remove the plastic protective sticker from all sides of the shelves and shelf brackets.

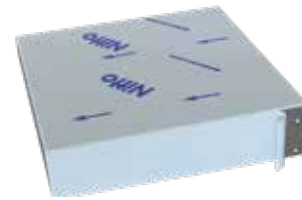

### Mount Side Shelf Brackets

- Locate the side brackets and mount the brackets to the right side of the grill.
- Attach the brackets using the supplied Phillips head bolts and Kep Nuts (2 Phillips head bolts and Kep Nuts per bracket).
- Insert the Phillips head bolts into the pre-drilled holes from the inside of the bottom casting and attach the Kep Nuts on the outside.
- Tighten the Kep Nuts while making sure the brackets remain parallel with the grill using a screwdriver and a 7/16" combination wrench.
- Follow the above steps to mount the brackets to the left side of the grill.



### Attach the Side Shelves

Once all brackets are in place, attach the side shelves.

- Insert the threaded stud on the left end of the bottom shelf into the slot on the left bottom bracket.
- Gently spread the shelf to align and insert the threaded studs on the right end into the right bottom bracket slot.
- **Tighten Nylock Nuts on the bottom threaded studs using a 3/8" combination wrench.** Make sure the nuts are snug but do not restrict movement of folding and unfolding of the shelf.
- Repeat steps to attached the second side shelf to the left side of the grill (*unless you have the Charmglow CHRM40B model grill*)

⚠ **Top threaded studs on shelf do NOT use nuts.**

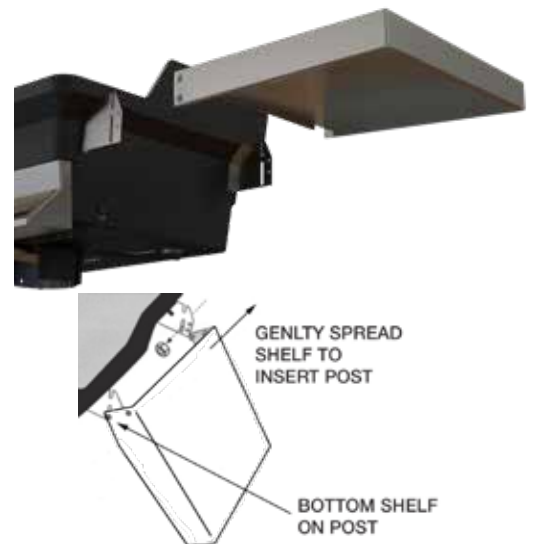

## STEP 7 INSTALL STAINLESS STEEL SIDE SHELVES, Continued

### Locking & Unlocking Side Shelves

#### To Lock Shelf

- Pull the shelf up until fully parallel to the ground and slightly higher than the bracket.
- Lower the shelf down into the bracket to lock.

#### To Unlock Lock Shelf

- Pull the shelf up until unlocked from the bracket.
- Lower the shelf down to store.

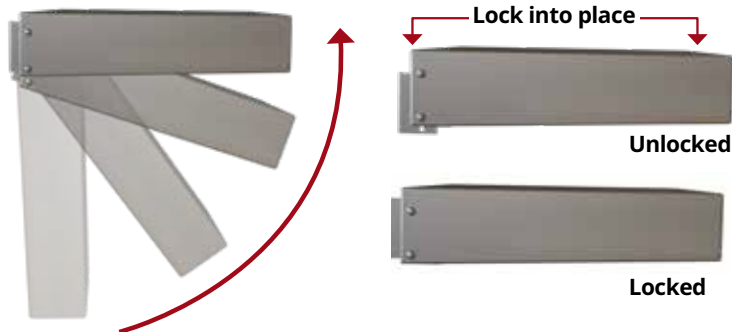

## STEP 8 INSTALL THE CAST ALUMINUM TOP CASTING



This step is easier with two people to help guide and stabilize the parts during assembly.

### PART INCLUDED



CAST ALUMINUM TOP CASTING

### HARDWARE INCLUDED

Included in Pillar Hardware Pack



LID PIVOT PIN  
(QTY. 2)



HITCH PIN  
(QTY. 2)

### Attach the Top Casting

- Position the top casting onto the back of the bottom casting, aligning the two back hinges.
- Insert the Lid Pivot Pin through both hinge holes and secure with a Hitch Pin.
- Repeat the process on the other side.



## STEP 9 INSTALL STAINLESS STEEL HEAT PLATE

### PART NEEDED

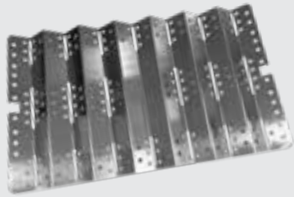

HEAT PLATE

### Identify the Correct Side of the Stainless Steel Heat Plate

When installing the one-piece heat plate, **ensure that the peaked ridges with the slit running along the top are facing downward, forming channels.** This orientation is critical for proper grease management and heat distribution.

**Do not install the heat plate with the slits facing upward as peaks.** If installed incorrectly, grease can collect in the upward-facing channels. This can lead to flare-ups, uneven cooking, and potentially create a fire hazard over time due to grease buildup.

**Always double-check the orientation during installation** to ensure safe and optimal grill performance.

### ✔ CORRECT PLACEMENT

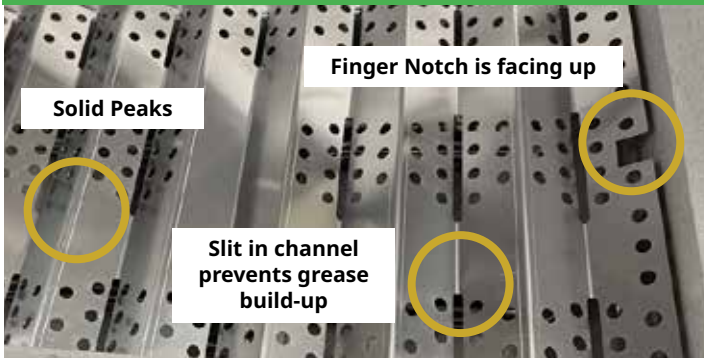

### ❌ Incorrect Placement



## STEP 10 INSTALL THE STAINLESS STEEL COOKING GRIDS

### PART NEEDED



COOKING GRIDS (2)

Your grill includes two stainless steel **channel-style cooking grids**, designed for optimal heat retention and performance. These grids must be installed side by side, resting securely on the front and back ledges of the bottom casting.

### Installation Instructions:

- **Orient each grid so the curved top surface is facing upward** (this is the cooking surface), and the open channels are facing downward toward the burners.
- **Place both grids side by side**, ensuring they rest firmly on the front and back ledges inside the grill's bottom casting.
- Double-check that each grid is seated evenly and securely before use.



## STEP 11 INSTALL THE STAINLESS STEEL WARMING RACK

### PART NEEDED

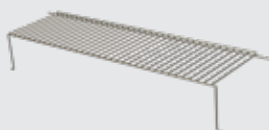

WARMING RACK

**The Swing-Away Warming Rack connects to both the grill lid and the grill bottom casting.**

- Insert the right top and bottom rods into their respective mounting holes on right side of the grill lid and grill bottom casting.
- Slide the Warming Rack to your left, positioning the left top and bottom rods into their respective mounting holes simultaneously.
- The lower right rod end can then be "popped" into place by flexing it inward.

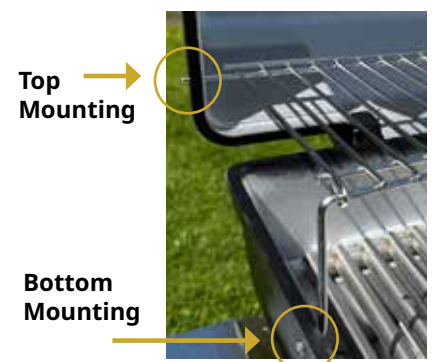

## STEP 12 INSTALL THE STAINLESS STEEL HANDLE

### PART INCLUDED



STAINLESS STEEL HANDLE

### HARDWARE INCLUDED



1/4-20 X 1-1/2"  
BOLTS (2)



GASKET (2)

### TOOL NEEDED:



7/16"  
COMBINATION  
WRENCH

### Attaching the handle

- The stainless steel handle has a tapered design—be sure to install it with the long end of the taper facing downward. When installed correctly, the handle should angle slightly upward.
- From the inside of the lid, insert the 1/4-20 x 1-1/2" bolts through the pre-drilled holes. *The handle is pre-threaded, so no nuts are required for this assembly.*
- On the outside of the lid, place the gasket over the threaded portion of each bolt and align the handle, ensuring the long end of the taper is facing down and the ends sit flush against the lid surface.
- Using a 7/16" combination wrench, tighten the bolts until secure.
- Do not over-tighten.

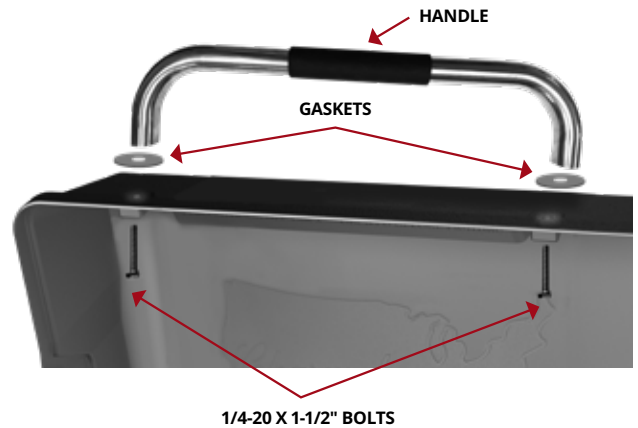

Handle ends taper to fit flush on the lid with a slight upward angle.



### CORRECT HANDLE INSTALLATION



### Incorrect Handle Installation



## STEP 13 INSTALL THE STAINLESS STEEL THERMOMETER

### PART INCLUDED



THERMOMETER

### Installing the thermometer

- Start by removing the nut from the threaded post of the thermometer.
- Insert the thermometer through the pre-drilled hole in the grill lid, ensuring the gauge faces outward.
- From the inside of the lid, thread the nut back onto the post and tighten it until it sits snug against the casting.
- **Do not overtighten.**

### HARDWARE INCLUDED

The hardware needed is threaded onto the thermometer post.



Nut on post



Nut removed from post



## GAS CONNECTIONS

### Check Local Codes

Consult your local LP dealer or Natural Gas Company for recommended installation procedures and regulations. In the absence of local codes, installation must conform to the National Fuel Gas Code, ANSI Z223.1 or CAN/CGA-B149.1 Natural Gas Installation Code or CAN/CGA-B149.2, Propane Installation Code.

### NATURAL GAS MODELS

The grill is designed to operate on Natural Gas at a pressure of 7" water column (W.C.) [1.75 kPa]. Check with your gas utility for local gas pressure. Use of your gas grill at pressures other than approximate 7" WC could affect the performance of your grill.

### Natural Gas Hose & Inspection

A single hose of not more than 10 feet long (3.6 meters) is supplied with the cart-styled models.

- Check the hose before each use at places where there could be extra bending, such as near the gas supply quick-disconnect coupling and at the grill valve connection. Look for cracking, cuts or heat damage. Check the entire length for cracking and excessive wear.
- To replace the hose, turn off gas supply at valve. Release the quick-disconnect coupling. Using a wrench, disconnect hose from grill valve connection under the control panel, and clean threads.
- Replace only with an identical hose from the manufacturer or an authorized dealer. Do not use pipe joint compound on the flared fitting at the control panel grill valve connection.

# LEAK TESTING

- ⚠️ LEAK TEST ALL GAS CONNECTIONS BEFORE USING YOUR GRILL.
- ⚠️ DO NOT SMOKE WHILE LEAK TESTING.
- ⚠️ DO NOT LEAK TEST WITH A MATCH OR OPEN FLAME.
- ⚠️ DO NOT USE A GRILL THAT IS LEAKING GAS.
- ⚠️ YOU SHOULD TEST FOR GAS LEAKS EVERY TIME YOU DISCONNECT AND RECONNECT A GAS FITTING.
- ⚠️ PERFORM A LEAK TEST EVEN IF YOUR GRILL WAS DEALER OR STORE ASSEMBLED.
- ⚠️ DO NOT IGNITE BURNERS WHEN LEAK TESTING.

Perform a leak test at least once a year whether the gas supply cylinder has been disconnected or not. In addition, whenever the gas cylinder is connected to the regulator or whenever any part of the gas system is disconnected or replaced, perform a leak test.

As a safety precaution, remember to always leak test your grill outdoors in a well-ventilated area. Never smoke or permit sources of ignition in the area while doing a leak test. Do not use a flame, such as a lighted match to test for leaks. Use a solution of soapy water.

1. Prepare a leak testing solution of soapy water by mixing in a spray bottle one part liquid soap to one part water.
2. Make sure all the control knobs are in the OFF position.
3. Turn on the gas.
  - a. On **natural gas systems**, turn the main feed valve to the grill.
  - b. On **LP systems**, turn the cylinder valve knob counter clockwise one turn to open.
4. Apply the leak testing solution by spraying it on joints of the gas delivery system. Bubbles in the soap solution indicate that a leak is present.
5. Stop a leak by tightening the loose joint or by replacing the faulty part with a replacement part recommended by the manufacturer. Do not attempt to repair the cylinder valve if it is damaged. The cylinder must be replaced.
6. Turn all control knobs back to the full OFF position.

### If a leak is detected...

If you have detected a leak try tightening and securing all connections. The use of two wrenches is recommended—one wrench is used to hold fitting while the other is used to tighten.



### If you are unable to stop a leak:

1. Turn all control knobs back to the full OFF position.
2. Shut off the gas supply to the grill and release pressure in the hose and manifold by pushing in and turning any of the control valves one quarter turn counter-clockwise.
3. On LP systems, remove the cylinder from the grill.
4. Call an authorized gas appliance service technician or an LP gas dealer.

***Do not use the appliance until the leak is corrected.***



- **If you cannot stop a gas leak by tightening, turn gas supply off.** Take leaking joint apart, clean it, reconnect and test again. If leak persists, contact dealer or gas utility.
- **A gas system MUST be tested yearly, or whenever the LP cylinder or any other gas system part is replaced.**

# GETTING TO KNOW YOUR GRILL

Your new Charmglow® Gas Grill is designed to deliver reliable, even heat, and the versatility needed for a wide range of outdoor cooking styles. Whether you're grilling burgers, slow roasting a pork shoulder, or smoking ribs, understanding your grill's features and operation is key to a great experience.

## Lighting the Grill

### To ignite your grill:

1. Open the lid fully.
2. Ensure all burner knobs are in the OFF position.
3. Open the gas supply valve (LP tank or natural gas line).
4. Push and turn the first burner control knob to the "START/HI" position and press the ignitor button. You should hear a click and see the burner ignite.
5. Once the first burner is lit, turn on the second burner if needed.
6. If the burner does not light within 5 seconds, turn the knob to OFF, wait 5 minutes for gas to dissipate, and try again.



**⚠️ Refer to the leak test and gas connection procedures before your first use.**  
*These steps can be found in the "Gas and LP Tank Connections" and "Leak Testing" sections.*

## If the Electronic Ignition Fails

### Your Charmglow grill can also be lit manually using a long fireplace-style lighter.

#### Follow these steps:

1. Open the lid fully.
2. Ensure all burner knobs are in the OFF position.
3. Insert the lit fireplace lighter through the designated manual lighting hole located under the right side shelf.
4. Once the lighter is in place and ignited, push and turn the first burner control knob to the "START/HI" position. The burner should ignite immediately.
5. After the first burner is lit, you may ignite the second burner by turning its control knob to the desired setting.

Manual Lighting Hole



**⚠️ Always use caution when manually lighting the grill. Keep your face and hands away from the cooking area**

## Preheating

**Preheat your Charmglow grill with both burners on HIGH for 10–15 minutes with the lid closed.** This heats the stainless steel cooking grids and the heat plate evenly, ensuring **optimal searing and minimizing flare-ups**. After preheating, the grids reach the ideal searing temperature. They also clean up easily with a brass-bristle brush while still warm.



### Cooking Grids Performance

Your grill includes stainless steel channel-style cooking grids, engineered for:

- Excellent heat retention
- Even heat distribution
- Long-lasting durability
- Reduced sticking and flare-ups

## GETTING TO KNOW YOUR GRILL, continued

### One-Piece Stainless Steel Heat Plate

Beneath the cooking grids lies the one-piece stainless steel heat plate.

**This component:**

- Disperses heat evenly across the cooking surface
- Prevents hot spots and flare-ups
- Channels grease away from burners
- Adds a layer of durability and protection

HEAT PLATE



Proper installation (slits facing down) ensures safe and consistent performance. *See installation step 9 for guidance.*

### Stainless Steel Warming Rack

Designed with convenience in mind, **the Swing-Away Warming Rack automatically lifts with the lid**, giving you full access to the main cooking surface while keeping your upper rack space ready for action. This smart design maximizes usable space and makes multitasking on the grill a breeze.

**The Swing-Away Warming Rack is ideal for:**

- Keeping food warm without overcooking
- Toasting buns
- Indirectly reheating leftovers

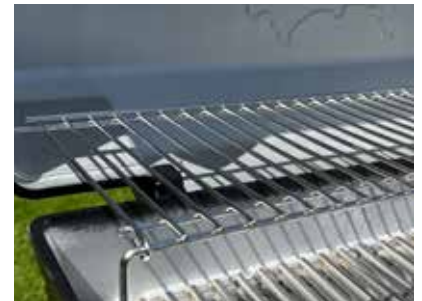

### Stainless Steel Dual Burner System and Independent Controls

Charmglow's dual burner system is all about control and versatility. With **independently controlled burners, you can tailor the heat to match your cooking style**—whether you're firing up a quick dinner or slow-roasting something special. This flexibility opens the door to a wide range of grilling techniques—all with precise temperature control at your fingertips.

**Charmglow's dual burner system with independent controls allows you to:**

- Grill over direct heat for high-temperature searing
- Create indirect zones for slow roasting or smoking
- Use only one side for small meals, saving fuel



**Tip:**

Always monitor internal food temperatures using a meat thermometer and utilize the built-in lid thermometer for ambient heat control.

PROBLEM	CAUSE	CHECK
<b>Yellow or orange flame and the smell of gas.</b>	<ol style="list-style-type: none"> <li>1. Blockage in the venturi tube or orifice.</li> <li>2. Orifice not seated properly in the venturi Tube.</li> <li>3. Bent or kinked hose.</li> </ol>	<ol style="list-style-type: none"> <li>1. Clean venturi. <i>(See Maintenance section)</i></li> <li>2. Orifice must fit into venturi tube at least ¼" to ½".</li> <li>3. Check gas supply line. Also, check all connections.</li> </ol>
<b>Burner does not light or flame is low in HIGH position.</b>	<ol style="list-style-type: none"> <li>1. Could be a kink in the gas supply line.</li> <li>2. LP tank could be low or empty.</li> <li>3. LP regulator excess flow feature has been activated.</li> </ol>	<ol style="list-style-type: none"> <li>1. Straighten.</li> <li>2. Refill LP cylinder.</li> <li>3. Turn grill control knobs off, close LP tank valve and reopen valve slowly. Wait 5-seconds before turning on grill valves.</li> </ol>
<b>Erratic flame pattern from burner or flame is low when burner control knob set at HIGH or flames do not run the whole length of burner.</b>	Dirty burner	Clean burner holes with a small pin. Be careful not to enlarge holes.
<b>Constant flare-ups</b>	<ol style="list-style-type: none"> <li>1. Grill too cold before start of cooking.</li> <li>2. Cooking grate or heat plate may be heavily coated with burned-on grease.</li> <li>3. Fatty foods.</li> <li>4. Heat setting too high.</li> </ol>	<ol style="list-style-type: none"> <li>1. You should always pre-heat grill for 5 to 10 minutes before cooking.</li> <li>2. Clean cooking grate and/or heat plate.</li> <li>3. Trim excessive fat from fatty meats.</li> <li>4. Lower heat setting.</li> </ol>
<b>Food sticks to cooking grid.</b>	<ol style="list-style-type: none"> <li>1. Cooking grid is probably too hot.</li> <li>2. Food being turned before sear lines are produced.</li> </ol>	<ol style="list-style-type: none"> <li>1. Lower heat setting. You'll need to experiment with heat setting to get the best results. Or use a non-stick cooking spray.</li> <li>2. Time food to turn over only once.</li> </ol>
<b>Flame blows out.</b>	During periods of high wind and sometimes while cooking on a low setting, flame may be extinguished.	<ol style="list-style-type: none"> <li>1. On cart, simply turn away from wind.</li> <li>2. Increase the heat setting.</li> </ol>
<b>Oxidation Graying of grill head.</b>	Due to extreme cooking temperatures and severe weather conditions the grill body may bleed through the paint and cause white spotting (Oxidation).	Use a wire brush, sandpaper and wash with mild soap to remove flaking paint and grease. Repaint with high quality heat resistant grill paint.
<b>Grill does not get hot.</b>	<ol style="list-style-type: none"> <li>1. See low flame above.</li> <li>2. On natural gas models, inadequate pressure at grill.</li> <li>3. Incorrect orifice.</li> </ol>	<ol style="list-style-type: none"> <li>1. See low flame above.</li> <li>2. Check pressure. Should be at or near 7" water column.</li> <li>3. Check orifice size.</li> </ol>



**CAUTION:**

If problems can not be corrected using these methods, contact your local Charmglow dealer for assistance.

# GRILLING TECHNIQUES

## Unlock the Full Potential of Your Charmglow Gas Grill

Your Charmglow grill isn't just for burgers and hot dogs—it's a versatile cooking tool that opens up a world of flavor. Whether you're searing a steak, slow-roasting a whole chicken, or whipping up weekend brunch on the griddle, knowing how to use different cooking techniques can elevate every meal.

Here's a quick guide to help you master a variety of methods on your Charmglow gas grill:

### DIRECT GRILLING

The most common method, direct grilling is all about fast, high-heat cooking.

**Great for:**

Steaks, burgers, hot dogs, kabobs

**How-to:**

Turn both burners to high or medium heat

- Place food directly over the flames
- Best for quick searing and bold grill marks

### INDIRECT GRILLING

When you need lower, slower, more even cooking, indirect grilling is your go-to.

**Great for:**

Whole chickens, roasts, large cuts of meat

**How-to:**

- Light one burner only
- Place food on the unlit side and close the lid
- Creates even, oven-like heat for thorough cooking

### ROTISSERIE

 **Recommended Accessory:**  
MHP's RKMHP Rotisserie Kit

Rotisserie cooking delivers juicy, evenly roasted meats by slowly turning them over indirect heat.

**Great for:**

Whole chickens, pork loins, roasts, and other large cuts

**How-to:**

- **Install a compatible rotisserie kit** and secure the food on the spit rod
- **Light one or both burners on low**, depending on grill size—food should rotate over indirect heat
- **Cook with the lid closed** to retain heat and ensure even cooking

### ROASTING

Roasting on the grill gives you that oven-style cook with a hint of char-grilled flavor.

**Great for:**

Vegetables, poultry, pork, or beef

**How-to:**

- Set one burner to medium or both burners to low
- Place food in the center or over the cooler side
- Close the lid to circulate heat evenly, like a convection oven

### SMOKING

 **Recommended Accessory:**  
MHP's SSST Stainless Steel Smoker Box

Add rich, wood-fired flavor to your grilling with this low-and-slow method.

**Great for:**

Ribs, brisket, poultry, or fish

**How-to:**

- Soak wood chips and place in a smoker box or foil pouch
- Position directly on the heat plate over a single burner set to low
- Place food on the opposite side and close the lid
- Maintain temperature between 225–275°F

### GRIDDLE COOKING

 **Recommended Accessory:**  
MHP's GGRIDL Stainless Steel Griddle

Expand your outdoor menu with flat-top favorites using a stainless steel griddle.

**Great for:**

Pancakes, bacon, eggs, stir-fry, smash burgers

**How-to:**

- Place the Stainless Steel Griddle over burners
- Preheat on low to medium heat
- Lightly oil the surface to prevent sticking

## Accessories That Amplify Your Grill's Power

Take full command of your outdoor cooking experience with expertly designed accessories that deliver precision, convenience, and elevated flavor.

### STAINLESS STEEL SIDE BURNER

SBA3-N | SBA3-P

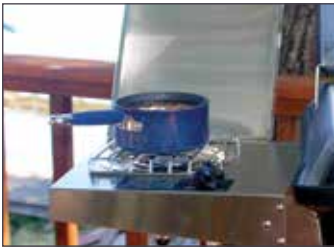

Upgrade your outdoor cooking setup with our powerful, easy-to-install Stainless Steel Side Burner—perfect for sauces, sides, and searing.

- 12,000 BTUs
- Premium commercial grade stainless steel
- Electronic ignition
- Simple bolt-on installation

### ROTISSERIE KIT

RKMHP



Take your grilling to the next level with this Rotisserie Kit—ideal for slow-roasting juicy, evenly cooked meats right on your grill.

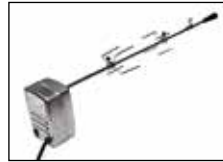

- INCLUDES:**
- RO6 stainless steel motor
  - 3ft. cord
  - Max. 25lb. balanced load

### HEAVY-DUTY STAINLESS STEEL GRIDDLE

GGGRIDL



Turn your grill into a flat-top cooking station—perfect for everything from breakfast to stir-fry.

- Constructed from thick, high-grade stainless steel for excellent heat retention and durability
- Built-in sidewalls and grease trough help keep food contained and flare-ups to a minimum
- Measures 11-15/16" x 16-3/4" to cover half the grill surface.



### STAINLESS STEEL SMOKER BOX

SSST



This smoker box features a removable vented lid so you can easily add your favorite smoking chips (*not included*). Ideal for infusing a classic smoked taste to meats and veggies.

- Stainless steel
- Measures 9" x 3-3/4" x 1-1/2"
- Adds a nice smoked flavor to your grilled food
- Smoking chips not included

## Protect Your Grill

Our grill covers are constructed of a durable polyester lined vinyl, designed to protect your grills from the elements.



Mid-Length Grill Cover  
Side Shelf Up  
GGCVPREM



Full-Length Grill Cover  
Side Shelf Up  
CV4PREM



Full-Length Grill Cover  
Side Shelves Down  
DDCVPREM

# MAINTENANCE

## Annual Maintenance

---

**After a period of non-use or to keep your grill in top operating condition, you should perform the following maintenance procedures to keep the grill ready for instant use and for your safety.**

- **Do not obstruct the flow of combustion and ventilation air.**
- **Clean inside the grill head.** Remove the burner/venturi assembly and cover the valve orifices with a piece of aluminum foil to keep out dirt. Brush the inside, bottom and sides with a stiff wire brush to remove built-up grease and debris. Be careful not to damage the ignitor or collector box.
- **Test the ignitor for a good spark.** (*See Ignitor System in Maintenance section.*)
- **The stainless steel burner** may be brushed lightly with a stiff laundry brush. Any clogged flame holes can be cleared using a thin wire. Clean the venturis using the supplied venturi cleaning brush, a bottle brush, or a pipe cleaner. (*See Flashback/Cleaning Venturis section.*)
- **Clean the control panel, side shelves, lid handle spacers, lower cart frame, and posts** with a mild detergent and warm water solution.
- **For stainless steel components** (such as the side shelves, control panel, and column), use a good non-abrasive stainless-steel cleaner of your choice. Avoid cleaners that contain bleach, powdered abrasives, steel wool, or caustic solutions such as oven cleaners, as these can permanently damage the finish.
- **For powder-coated components**, including the column base and grill casting, clean using a soft cloth and a mild non-abrasive detergent. Do not use abrasive tools or harsh chemicals.
- **Stainless steel cooking grids should be cleaned by preheating the grill on high for 10–15 minutes with the lid closed.** After preheating, use a brass-bristled grill brush to remove food residue. For a deeper clean, the grids can be removed and treated with a suitable oven cleaner or cleaned using one of the new steam-based grid cleaners that work with water. Always rinse thoroughly and dry before reinstalling.
- **Stainless steel heat plates (flame tamers) should be maintained regularly** by burning off residue after each use (run the grill on high for 10–15 minutes with the lid closed), then brushing clean with a brass-bristled brush or non-abrasive pad once cooled. For heavy buildup, remove the plates and soak in warm soapy water or use a grill-safe oven cleaner. Avoid steel wool or harsh chemicals that may damage the finish.
- **Occasional white oxidation on the grill lid or other painted surfaces can be washed off with mild soap and warm water.**
- **Severe weathering of the grill lid can be treated by lightly sanding or rubbing with steel wool to remove surface corrosion or oxidation.** Recoat the surface using a good high-temperature grill paint available at most hardware or grill supply stores.
- **Inspect the hose and gas fittings.** Remember to perform a leak check every time you disconnect and reconnect any gas fittings.
- **Keep the ventilation openings of the LP cylinder enclosure free and clear of debris.**

## Spark Test & Troubleshooting

### CHECK SPARK

**With the gas off**, use a mirror to view inside the collector box while pressing the ignitor button in low light.

#### 1. If there's a good spark, but the grill won't light

- Gas may not be flowing to the burner and into the collector box.
- The gas orifice or the venturi tube may be blocked.
- **To clean, follow "Flashback" instructions.**

#### 2. If a weak spark arcs down around the ceramic insulator

- The insulator should be cleaned
- The insulator has a coating of grease or it is wet.
- Use an old tooth brush to break up the conductive electric path.

#### 3. If there's no spark, check for the following:

- Loose wire connections at the ignitor or electrode.
- Damaged or corroded ceramic insulator—clean with a toothbrush or replace if cracked.
- Loose ignitor button/module—tighten to ensure a proper ground.



Good Spark



Weak Spark

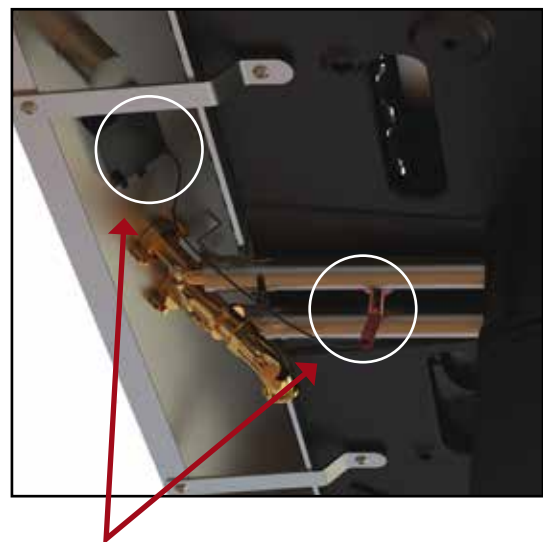

Check Connections

### TEST SPARK WIRE

- Disconnect it from the electrode and hold the tip about 1/8" from metal while pressing the ignitor.
- **If no spark appears, replace the ignitor module.** If there is a spark, replace the collector box/electrode.
- **Make sure Ignitor Button module is tight on the control panel.** If it is loose a good ground will not be attained.



Hold Connector 1/8" from panel bottom. Press button.

## MAINTENANCE, continued

### Switch Ignitor Battery

If you do not hear any clicking when you push the ignitor button, it may be time to replace the battery.

- **Unscrew and remove the ignitor push button** from the control panel.
- **Remove the old AAA battery.** If corrosion is present in the battery compartment, wrap a small piece of sandpaper around the eraser end of a pencil and gently clean the contacts.
- **Insert a new AAA battery**, positive (+) side down.
- **Reinstall the push button** and ensure it is screwed on tightly to maintain proper grounding.



### Ignitor Module Replacement

If replacing the battery does not restore spark:

1. **Remove the ignitor push button** by unscrewing it from the control panel.
2. Underneath the button, you'll find a **black plastic collar/nut** securing the module to the control panel. Unscrew this collar to release the module.
3. Once the collar is removed, the **old ignitor module will fall out from the back side** of the control panel.
4. Install the **new ignitor module** from the rear of the control panel.
5. Reinstall the **black collar/nut** from the front and tighten to secure the module in place.
6. Insert a new **AAA battery (positive side down)**, then screw the push button back on.



### Electrode Replacement or Adjustment

The electrode is preset at the factory to sit approximately 1/8" from the inside surface of the collector box.

To inspect or replace:

1. **Turn off the gas** and allow the grill to cool.
2. **Loosen the large nut** beneath the collector box and remove it.
3. **Check or set the spark gap to 1/8"**.
4. **Adjust by loosening the two jam nuts** on the electrode and sliding it into proper position.
5. **Tighten securely and reinstall the collector box.**

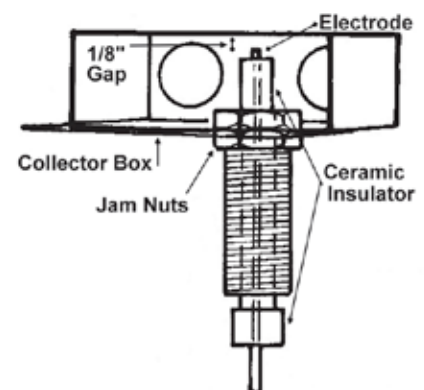

## Flashbacks/Cleaning Venturis

In some areas of the country, spiders and other insects build nests, lay eggs and spin webs in the grill's venturi tube or valve orifice. This obstructs the full flow of gas to the burner. Some gas backs up resulting in a **"Flashback"**— a fire in the venturi behind the control panel which could cause serious bodily injury or damage to your grill.

To remove spider webs and/or other obstructions, you must clean out the venturis. **This should be done routinely if the grill has sat idle for extended periods. Also, if you live in an area where spiders are plentiful, you should clean the venturis often, especially in the fall when there is an increase in egg sack production.**

**To clean, be sure the grill is cold. Open lid and remove the cooking grids and heat plate.**

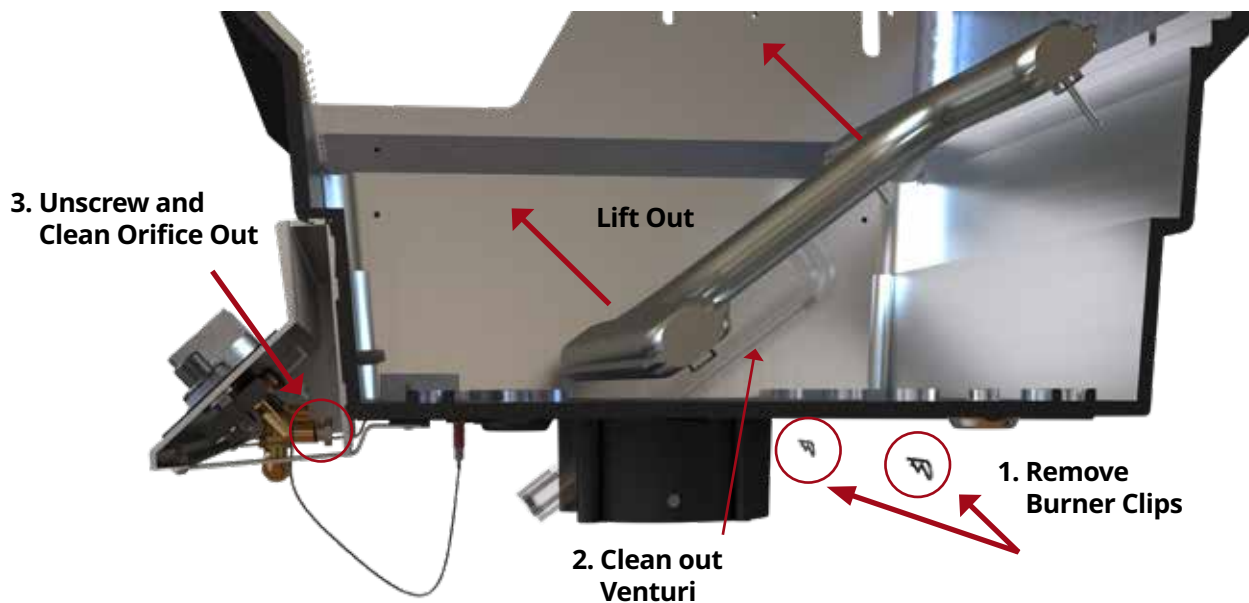

### 1. Remove the burner

Remove the grill burner by taking out the burner clips located under the bottom of the grill head then, pull the burner up and out of the grill head.

### 2. Clean the Venturi

With the brush supplied (VTCB), pipe cleaner or long flexible wire, clean out the venturi tubes.

### 3. Remove the hex head orifice with a 3/8" wrench

Clean orifice hole and inner part of the valve with a toothpick being careful not to enlarge the orifice hole.

### 4. Remove loose debris

Before reinstalling the hex head orifice to the valve stem, use a quick burst of gas pressure by turning the valve on then off to remove any loose debris.

### 5. Reinstall Burner/Venturi

When replacing the burner/venturi assembly, be sure the venturis fit over the gas valve orifices.

### 6. Reinstall Clips

Reinstall the clips under the grill to hold the burner in place.



### VTCB | Stainless Steel Venturi Brush

Specially designed flexible brush to clear venturis of spider webs and other obstructions that can cause flashback fires.

Visit [charmglowgrill.com](http://charmglowgrill.com) for helpful videos covering cleaning, maintenance and troubleshooting your grill.

# MAINTENANCE, continued

## Flare-Ups: Causes and Prevention

Below are the most common causes of flare-ups and steps you can take to avoid or reduce them.

### Grill Not Properly Preheated

- Always preheat the grill for 10 to 15 minutes before cooking.
- This ensures the heat plate is properly warmed and helps maintain even heat, reducing the chance of flare-ups.

### Grease Buildup on Cooking Grids

**Grease accumulation on the underside of cooking grids is a leading cause of flare-ups. To prevent this:**

- When the grill is hot, use a brass-bristle brush to remove food and grease residue.
- Alternatively, remove the grids and wash with warm water and mild dish soap. Rinse thoroughly and allow to dry before reinstalling.

### Grease Buildup on Heat Plates

**Grease accumulation on the heat plates can also cause flare-ups. To prevent this:**

- Once cool, remove the heat plates and scrub with a brass-bristled brush or non-abrasive pad.
- For stubborn buildup, soak in warm, soapy water or treat with a grill-safe oven cleaner.
- Rinse thoroughly and dry before reinstalling.

### Grilling Fatty Foods

**High-fat foods are more likely to drip grease, leading to flare-ups. To reduce the risk:**

- Trim excess fat from meats before grilling.
- Move food to a new location on the grill when flipping, so fat doesn't repeatedly drip in the same spot.
- Ensure the grill interior is clean before cooking.

### Heat Setting Too High

**Cooking on excessively high heat increases the likelihood of flare-ups.**

- Lower the heat setting as needed.
- When searing fatty meats, grill with the lid open to allow heat and vapor to escape.

## WHAT TO DO IF A FLARE-UP OCCURS

Flare-ups can happen fast—follow these steps to safely control the situation:

### 1. Turn off the burners.

Use the control knobs to shut off the gas supply. If the knobs are too hot to touch, use an oven mitt, or tongs for protection.

### 2. Smother the flames.

Once the gas is off, cover the flames with baking soda, salt, or sand—whichever is available. Do not use flour or sugar, as they can ignite.

### 3. Close the lid and vents.

This cuts off the oxygen supply and helps suffocate the fire.

### 4. Use a fire extinguisher if needed.

If the flare-up continues or grows, use a Class B or multipurpose (ABC) fire extinguisher.

 If you do not have a fire extinguisher and the fire becomes large—or if your gas tank is involved—**GET OUT IMMEDIATELY AND CALL 911.**

 **NEVER throw water on a grease fire.** Water can cause burning grease to splatter and spread the fire rapidly.

## Stainless Steel Cooking Grids

- Preheat the grill on high with the lid closed for 10–15 minutes to loosen food residue.
- Use a brass-bristled grill brush to scrub off debris.
- For deep cleaning, remove the grids and:
  - Soak in warm, soapy water, or
  - Use a grill-safe oven cleaner, or
  - Try a steam-based grid cleaner with water for a chemical-free option.
- Rinse and dry completely before reinstalling.

**Avoid using stainless steel brushes, steel wool, or harsh abrasives.**

## Stainless Steel Heat Plate (Flame Tamer)

- After each use, run the grill on high for 10–15 minutes with the lid closed to burn off grease.
- Once cool, remove the heat plates and scrub with a brass-bristled brush or non-abrasive pad.
- For stubborn buildup, soak in warm, soapy water or treat with a grill-safe oven cleaner.
- Rinse thoroughly and dry before reinstalling.

**Do not use steel wool or harsh cleaners.**

## Stainless Steel Surface Care

- **Clean:** Use a sponge or soft cloth with warm water and mild dish soap. Formula 409 or Fantastik may be used for heavier soil.
- **Rinse and Dry:** Wipe down with clean water and dry immediately with a towel.
- **Polish:** Apply WD-40 or Sheila Shine on a soft cloth and wipe with the grain. Buff off excess with a clean towel to avoid streaks.

**Repeat regularly to maintain shine and protect against corrosion.**

## Powder-Coated Surface Maintenance

- **Clean regularly** using a soft cloth or sponge and a solution of mild dish detergent and warm water.
- **Avoid** using abrasive pads, scouring powders, or steel wool, as these can scratch or damage the powder-coated finish.
- **For stubborn spots**, use a non-abrasive cleaner that is safe for painted surfaces—do not use bleach, oven cleaner, or solvent-based degreasers.
- **Rinse thoroughly** with clean water and dry completely with a soft towel to prevent spotting or oxidation.
- **If surface gloss begins to fade**, a light application of automotive wax can help restore shine and add protection.
- Do not use pressure washers on powder-coated surfaces, as high pressure can damage the coating.

**Regular cleaning not only keeps the finish looking good but also helps prevent rust or corrosion from forming beneath chipped or worn areas.**

### CLEANING PRODUCTS & MATERIALS

 **DO NOT USE** these common cleaning products and materials—they will damage your stainless steel or powder-coated surfaces.

- CLR
- Lime-Away
- Oven cleaner
- Ammonia
- Bleach
- Chlorine
- Steel wool pads
- Wire brushes
- Scrapers
- Pumice
- Cleansers such as Ajax or Comet

 **We recommend this product for stains, rust & discoloration:**

- MHP's SCC Cleaner  
*(follow directions on bottle)*

 **We recommend these products for cleaning stainless steel:**

- Mild dish detergent such as Dawn
- Formula 409
- Fantastik
- Instant Rust Out (exterior ONLY)
- WD-40 (exterior ONLY)
- Sheila Shine (exterior ONLY)

 **We recommend these products for cleaning powder-coated surfaces:**

- Mild dish detergent such as Dawn
- Automotive wax *(shine & protection)*

# Charmglow Grills Warranty

When you invest in a gas grill, you want peace of mind that it'll fire up for seasons to come.

Our warranty coverage is designed to back you up with quality craftsmanship and long-lasting performance. The following outlines the coverage and support you can expect—ensuring confidence in your purchase and continued satisfaction for years to come.



## 10-YEAR WARRANTY ON THE FOLLOWING:

*(Against Rust Through)*

- Cast Aluminum Grill Top & Bottom Casting
- Stainless-Steel Control Panel
- Stainless-Steel Column & Base
- Stainless-Steel Burner
- Stainless-Steel Cooking Grid
- Stainless-Steel Side Shelves
- Stainless-Steel Swing Away Warming Rack
- Aluminum Posts & Nu-Stone Base



## 5-YEAR WARRANTY ON THE FOLLOWING:

*(Against Rust Through)*

- Painted Aluminized Steel Column
- Stainless-Steel Heat Plate



## 1-YEAR WARRANTY ON THE FOLLOWING:

All other Components Including;

- Ignition System
- Gas Valves
- Casters
- Knobs

- **30-Day Warranty on Paint**
- **Anything not stated above falls under the 1-Year Warranty**
- **There is a 1-year warranty on all parts if grills are put into commercial, multi-unit or community use.**



## WHAT IS NOT COVERED

- Surface Corrosion and Discoloration
- Transportation and shipping cost
- Labor for replacement or repairs
- Damage from accident, misuse, alteration, abuse, improper installation or storage
- Removal and re-installation costs
- Finishes on surface that are damaged by improper installation, improper storage, accident, misuse, abuse or alteration
- Inoperable due to improper installation or storage
- The costs of a service call to diagnose a problem
- All warranties are non-transferable and apply only to the original purchaser

- This warranty does not imply or assume any responsibility for consequential damages that might result from use, misuse, or improper installation of this cooking appliance.
- This warranty does not cover claims, which do not involve defective workmanship or materials.

The warranty does not imply or assume any responsibility for consequential damages that might result from use, misuse, or improper installation of this cooking appliance.

This warranty does not cover claims which do not involve defective workmanship or materials.

**A BILL OF SALE, CANCELLED CHECK, OR PAYMENT RECORD SHOULD BE KEPT TO VERIFY PURCHASE DATE AND ESTABLISH WARRANTY PERIOD.**

**Be sure to register your new Charmglow® grill to activate your warranty and streamline any future service or support.**

Registration allows us to keep a record of your model and purchase date—key details for warranty coverage. It only takes a few minutes—**just scan the QR code or visit [www.charmglowgrill.com/register](http://www.charmglowgrill.com/register) to get started.**

