

"CARRINGTON" (FAUX) SLATE FIREPLACE

FA874900TX—IVORY

FA875200TX—BLACK

FA875500TX—CLASIC MAHOGANY

FA875600TX—WHITE

Assembly Instructions



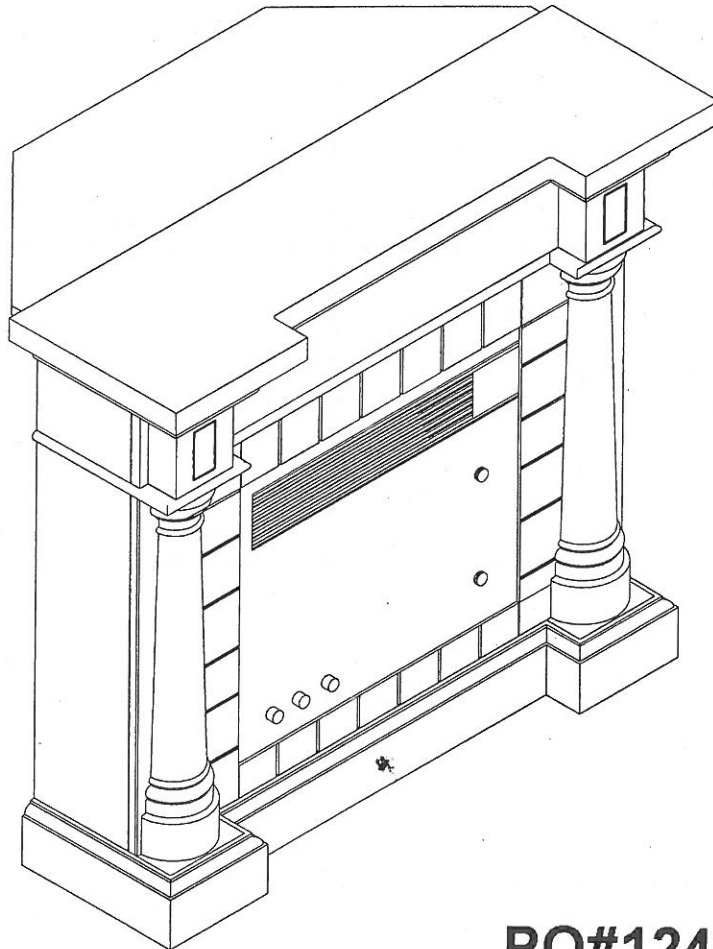

For assistance with assembly contact:
Southern Enterprises Inc.
Customer Service 1-800-633-5096
service@seidal.com
www.seidal.com



PO#12412

(FAUX) SLATE FP(WITH CONVERTIBLE TOP) Parts List

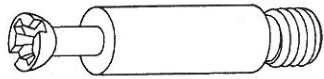
Please review all parts and hardware before disposing of any packaging. Call Customer Service if missing hardware. Do not return to store/retailer. Screws shown in actual size. Using a screw that is too long will cause damage. Before beginning assembly, separate each type of screw. Carefully study the screw diagrams below (SHOWN ACTUAL SIZE). You may receive extra hardware with your unit.

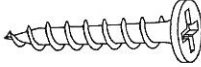
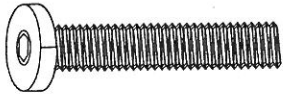
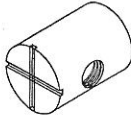
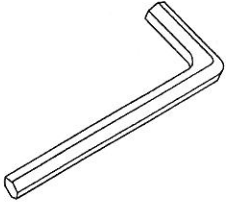
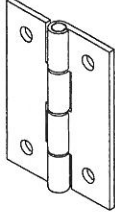
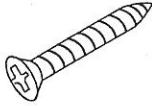
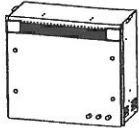
<p>A Quantity of 17</p>  <p>CAM BOLT</p>	<p>B Quantity of 16</p>  <p>WOOD DOWEL</p>
<p>C Quantity of 17</p>  <p>CAM LOCK</p>	<p>D Quantity of 10</p>  <p>FLAT HEAD LONG SCREW</p>
<p>E Quantity of 6</p>  <p>SOCKET HEXAGON SCREW</p>	<p>F Quantity of 6</p>  <p>CAM NUT</p>
<p>G Quantity of 1</p>  <p>SOCKET HEAD WRENCH</p>	<p>H Quantity of 3</p>  <p>HINGE</p>
<p>I Quantity of 12</p>  <p>FLAT HEAD SCREW</p>	<p>Quantity of 1</p>  <p>FIREBOX W/SCREEN KIT X1PC SHIPPED IN A SEPARATE CARTON.</p>

(FAUX) SLATE FP(WITH CONVERTIBLE TOP) Parts List

Please review all parts and hardware before disposing of any packaging. Call Customer Service if missing hardware. Do not return to store/retailer. Screws shown in actual size. Using a screw that is too long will cause damage. Before beginning assembly, separate each type of screw. Carefully study the screw diagrams below (SHOWN ACTUAL SIZE). You may receive extra hardware with your unit.

(1)

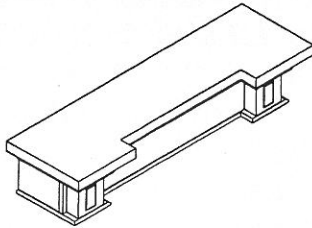

Quantity of 1

TOP PANEL

(2)

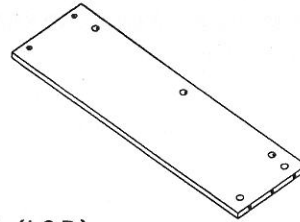

Quantity of 2

SIDE PANEL (L&R)

(3)

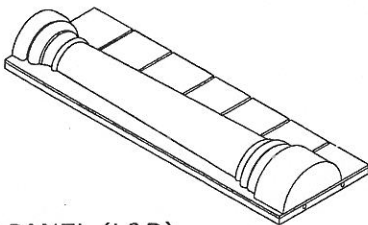

Quantity of 2

FRONT PANEL (L&R)

(4)

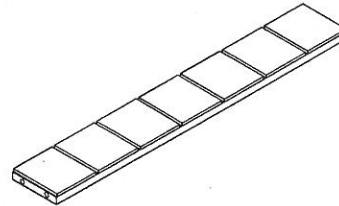

Quantity of 1

UPPER FRONT PANEL

(5)

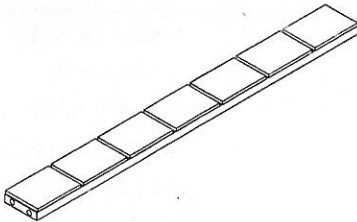

Quantity of 1

BELOW FRONT PANEL

(6)

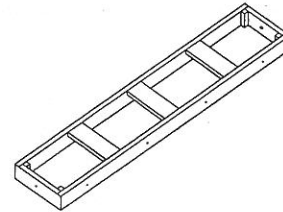

Quantity of 1

FIREBOX SUPPORT

(7)

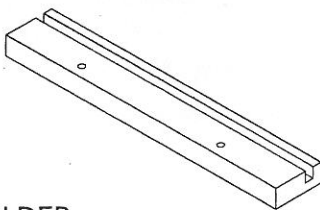

Quantity of 2

WOOD HOLDER

(8)

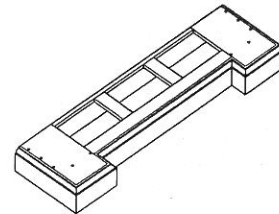

Quantity of 1

BOTTOM FRAME

(9)

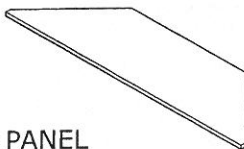

Quantity of 1

TRIANGLE TOP PANEL

MAXIMUM LOADING NOT TO EXCEED 20LBS

Care and Cleaning Instructions:

Before using, wipe with a clean, dry cloth. Periodically apply furniture wax to renew the finish. Avoid rubbing or scratching the surface with rough or abrasive objects.

For replacement parts or questions, please Call Customer Service at 1-800-633-5096 Do not return product to store, please call Manufacturer for assistance, questions or Parts.

Assembly Tool Required
No.2 Phillips Screwdriver (Not Included)

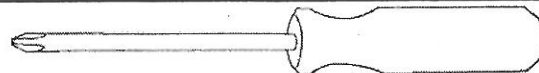

(FAUX) SLATE FP(WITH CONVERTIBLE TOP) Assembly Instructions

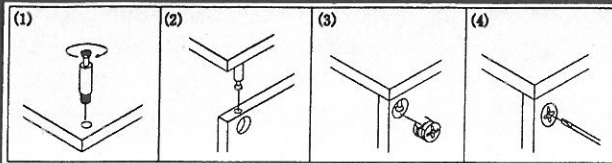

"Please do not over tighten cambolts. Please stop when you feel tight"

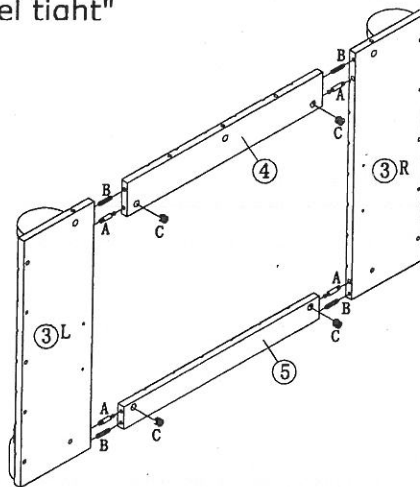

Figure 1

INSERT 4PCS WOOD DOWEL (B) & 4PCS CAM BOLT(A) ONTO CORRESPONDING HOLE OF LEFT AND RIGHT FRONT PANEL(3), THEN INSERT 4PCS CAM-LOCKS (C) INTO BIG HOLES OF UPPER&BELOW FRONT PANELS(4.5) WITH SLOT FOR SCREWDRIVER FACING OUTWARD. ROTATE CAM-LOCKS (C) CLOCKWISE TO SECURE CAM-BOLTS (A). AS FIGURE1 SHOWN.

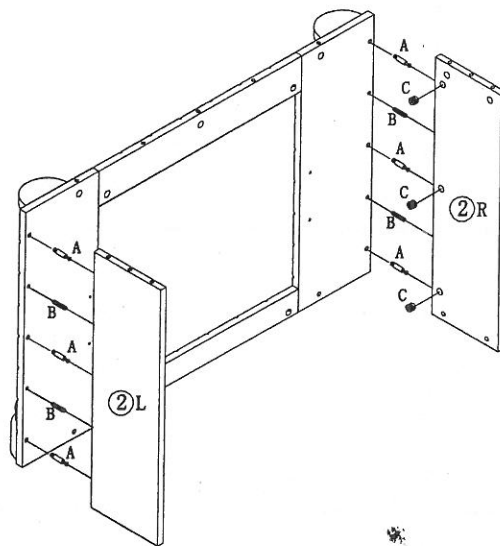

Figure 2

INSERT 4PCS WOOD DOWEL (B) & 6PCS CAM BOLT(A) ONTO CORRESPONDING HOLE OF LEFT AND RIGHT FRONT PANEL(3), THEN INSERT 6PCS CAM-LOCKS (C) INTO BIG HOLES OF LEFT AND RIGTH SIDE PANELS(2) WITH SLOT FOR SCREWDRIVER FACING OUTWARD. ROTATE CAM-LOCKS (C) CLOCKWISE TO SECURE CAM-BOLTS (A). AS FIGURE2 SHOWN.

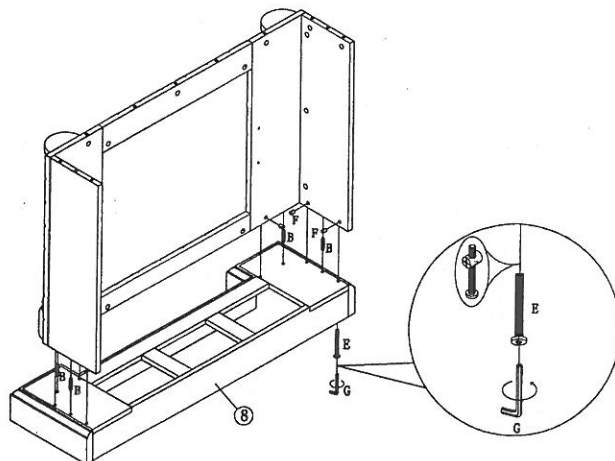

Figure 3

INSERT 4PCS WOOD DOWEL(B) AND 6PCS SOCKET HEXAGON SCREW(E) TO CORRESPONDING HOLES OF BOTOOM FRAME(8) AND PLACE THE ASSEMBLED UNIT OF FIGURE 5 ONTO BOTTOM PANEL UPRIGHTLY. THEN INSERT CAM-NUT (F) INTO CORRESPONDINIG HOLES, AND TIGHTEN (E) WITH SOCKET HEAD WRENCH(G); AS FIGURE3 SHOWN.

(FAUX) SLATE FP(WITH CONVERTIBLE TOP) Assembly Instructions

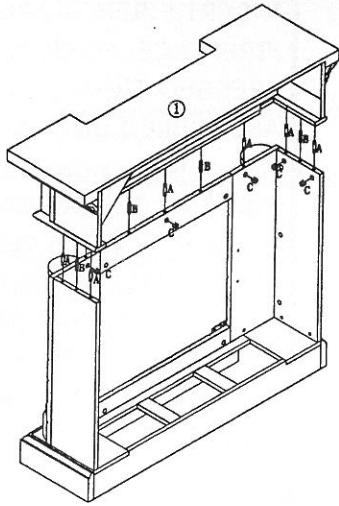

Figure 4

INSERT 7PCS CAM BLOT (A) AND 4PCS WOOD DOWEL (B) INTO PREDRILLED HOLES OF TOP PANEL(1),AND THEN INSERT 7PCS CAM-LOCK(C) INTO BIG HOLES OF SIDE PANEL AND FRONT PANEL AND UPPER FRONT PANEL(2.3.4) TO ASSEMBLE TOP PANEL(1) AND PREASSEMBLED FRAME TOGETHER.AS FIGURE4 SHOWN.

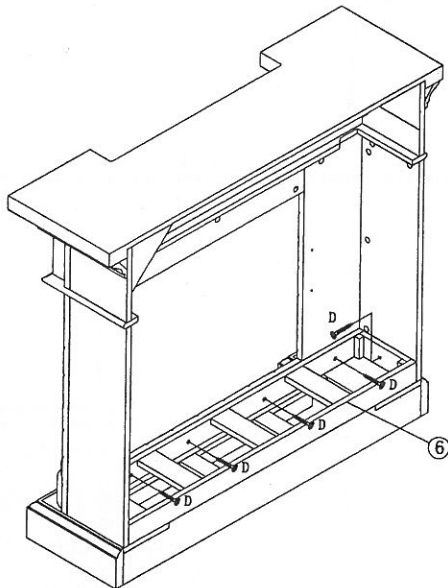

Figure 5

PUT FIXBOX SUPPORT (6) ONTO CORRESPONDING FRAME, AND FIX IT BY 6PCS FLAT HEAD LONG SCREW (D).

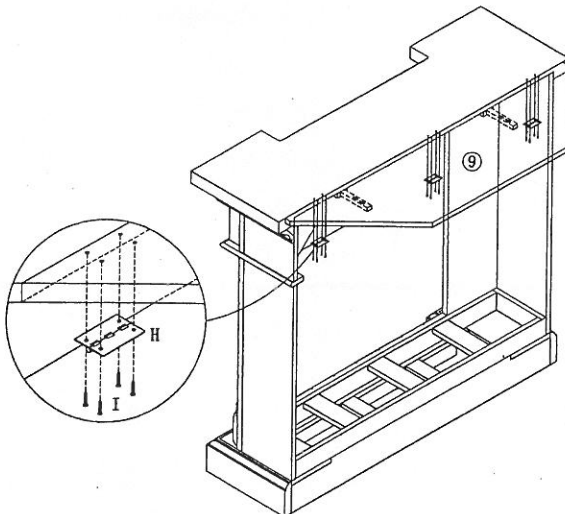

Figure 6

USE 3PCS HINGE(H) AND 12PCS FLAT HEAD SCREW(I) TO ASSEMBLE TRIANGLE TOP PANEL(1) AND TRIANGLE TOP PANEL (9) TOGETHER; AS FIGURE6 SHOWN.

(FAUX) SLATE FP(WITH CONVERTIBLE TOP) Assembly Instructions

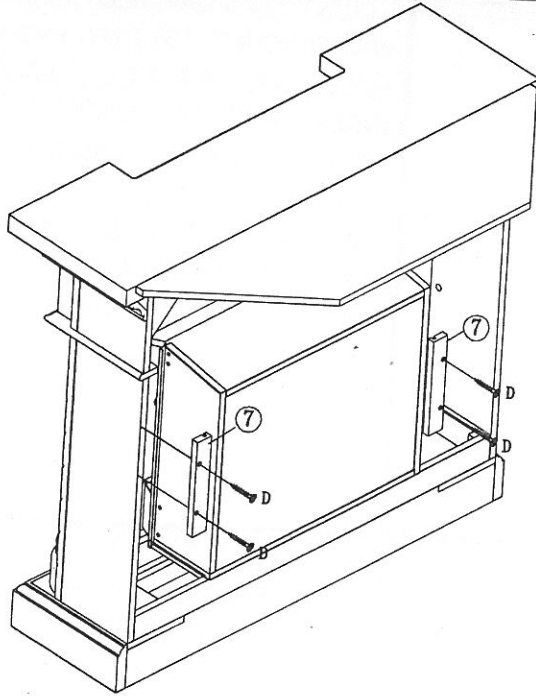

Figure 7

INSERT FIREBOX FROM THE BACK OF FIREPLACE. MAKE SURE FIREBOX IS PRESSED TIGHTLY AGAINST THE ASSEMBLED UNIT. ATTACH WOOD HOLDERS (7) ON THE SIDES OF FIREBOX. INSERT 4PCS FLAT HEAD LONG SCREW (D) THROUGH PREDRILLED HOLES ON WOOD HOLDER (7) AND TIGHTEN INTO CORRESPONDING HOLES ON BACK OF LEFT AND RIGHT FORNT PANELS (2.3). AS FIGURE 7 SHOWN.

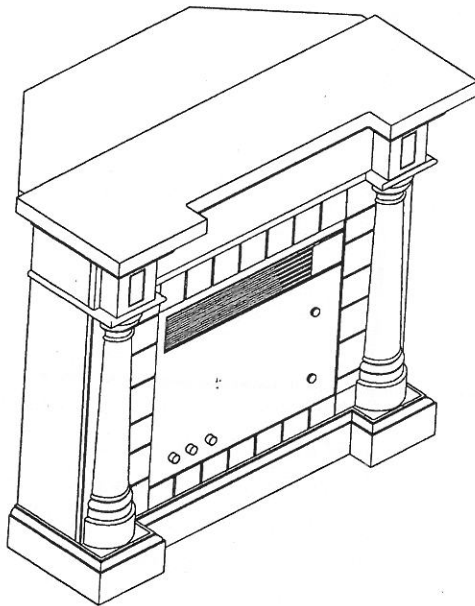

Figure 8

NOW, YOU CAN ENJOY IT.