



ELECTRIC GRILL

INSTALLATION INSTRUCTIONS AND OWNER'S MANUAL

INSTALLER: Leave these instructions with consumer.
CONSUMER: Retain for future reference.



Pedestal model shown

IMPORTANT: READ THESE INSTRUCTIONS CAREFULLY BEFORE STARTING INSTALLATION OR USE.

SAFETY AND WARNING CODES

PLEASE READ AND FOLLOW

- Removing permanently affixed rating warning labels **WILL** void the warranty.
- Observe all local codes and ordinances when installing this appliance. If no local codes are applicable, wire unit in accordance with the latest National Electrical Code, ANSI/NFPA 70, or the Canadian Electrical Code, CSA C22.1, whichever is applicable.

⚠ WARNING

Improper installation, adjustment, alteration, service, or maintenance can cause injury or property damage. For proper installation, refer to the installation instructions. For assistance or additional information, consult a qualified professional installer or service agency.

⚠ WARNING

When connecting this appliance to a power supply make sure that it is the same voltage as the unit rating. Improper connection may cause severe damage to the components or decrease the performance of your Fire Magic® electric grill. A rating plate specifying voltage, hertz, wattage, and amps is attached to the unit and also located on page 3. To avoid the risk of property damage and/or personal injury, installation work and electrical wiring must be performed by a qualified professional installer. This appliance must be installed in accordance with this instruction.

⚠ WARNING

To minimize the risk of property damage and/or personal injury, do not use a flexible extension power-supply cord unless it conforms with the specifications as listed in this manual (see page 7 for details).

NOT FOLLOWING THESE INSTRUCTIONS EXACTLY WILL VOID THE MANUFACTURER'S WARRANTY.

Certified to: UL 1026-2007



254-B-22-2



ELECTRIC GRILL

INSTRUCTIONS D'INSTALLATION ET MANUEL DU PROPRIÉTAIRE

INSTALLATEUR : Laissez ces instructions avec le consommateur.
CONSOMMATEUR : Maintenez pour la future référence.



Modèle de piédestal montré

IMPORTANT: LISEZ CES INSTRUCTIONS SOIGNEUSEMENT AVANT DE COMMENCER L'INSTALLATION OU L'UTILISATION.

SÛRETÉ ET CODES D'AVERTISSEMENT

SVP LISEZ ET SUIVEZ

- L'enlèvement de manière permanente a apposé des avertissements d'étiquette d'estimation videra la garantie.
- Observez tous les codes et ordonnances locaux en installant cet appareil. Si aucun code local n'est applicable, unité de fil selon le plus défunt code électrique national, ANSI/NFPA 70, ou le code électrique canadien, CSA C22.1, celui qui est applicable.

⚠ AVERTISSEMENT

L'installation inexacte, l'ajustement, le changement, le service, ou l'entretien peuvent causer des dommages ou des dégâts matériels. Pour l'installation appropriée, référez-vous aux instructions d'installation. Pour l'aide ou l'information additionnelle, consultez un installateur ou une agence professionnelle qualifiée de service.

⚠ AVERTISSEMENT

En reliant cet appareil à une alimentation d'énergie assurez-vous que c'est la même tension que l'estimation d'unité. Le raccordement inexact peut endommager considérablement les composants ou diminuer l'exécution de votre gril électrique de Magic® du feu. Une plaque de contrôle indiquant la tension, les hertz, la puissance en watts, et les ampères est attachée à l'unité et également située à la page 3. Pour éviter le risque de dégâts matériels et/ou de blessures, le travail d'installation et le câblage électrique doivent être exécutés par un installateur professionnel qualifié. Cet appareil doit être installé selon cette instruction.

⚠ AVERTISSEMENT

Pour réduire au minimum le risque de dégâts matériels et/ou de blessures, n'employez pas une prolongation flexible puissance-fournissent la corde à moins qu'elle se conforme aux caractéristiques comme énuméré en ce manuel (voir la page 7 pour des détails).

NON SUIVANT CES INSTRUCTIONS EXACTEMENT VIDERONT LA GARANTIE DU FABRICANT.

Certifié à: UL 1026-2007



254-B-22-2

CONTENTS

3	PRODUCT DATA TABLE
4	PARTS LIST
5	IMPORTANT SAFEGUARDS
6	ENSURING PROPER AIRFLOW
6	COUNTERTOP MODELS
6	PEDESTAL MODELS
6	INSTALLATION REQUIREMENTS
6	INSTALLATION
7	INNER LINERS
7	CONNECTING TO ELECTRICAL OUTLET
7	EXTENSION CORDS
7	OPTIONAL ROTISSERIE
8	THERMOMETER/THERMOSTAT
8	OPERATION
9	COOKING ELEMENT
9	OPTIONAL ROTISSERIE
10	DROP DOWN SHELF
11	FIRE MAGIC® DRIP TRAY
12	CARE & CLEANING
13	TROUBLESHOOTING
14	WARRANTY

PRODUCT DATA TABLE

Specification	Value	
	Pedestal model	Countertop model
Unit height	43" (lid closed) / 57" (lid open)	14" (lid closed) / 28" (lid open)
Unit width	25" (shelves down) / 42" shelves up)	19"
Unit depth	20"	20"
Approximate weight	76lbs	42lbs

Specification	Value
	All models
Electrical requirements	120 volts, 60 hertz, 20 amp; GFI outlet.*
Cook element rating	120 volts 1800 watts 15 amps 60 hertz
* See INSTALLATION section for important details regarding GFI outlets and extension cords.	

Table 1 - Product Data Table

PARTS LIST

Item	Part No.	Description
1.	3549	Cooking grids, 1 pair
2.	23115-01	Element
3.	23115-02	Inner liner kit
4.	23115-26	Handle assy
5.	23115-51	Oven lid assy
6.	3680	Warming rack
7.	23115-12	Digital thermometer
8.	23115-13	Thermometer harness (not shown)
9.	23115-07	Control panel w/ power cord & electronics
10.	23115-14	Meat probe
11.	3086	Drip tray
12.	23115-09	Bumpers, set of 4 *
13.	25115-015	Drop down shelf (2) †
14.	25115-03	Post assy †
15.	3604S	Rotisserie kit ‡
16.	3557	Drip tray liners, set of 4 ‡ (1 sample liner included)
17.	3642	Countertop cover (not shown) ‡
18.	5115-20	Pedestal cover (not shown) ‡

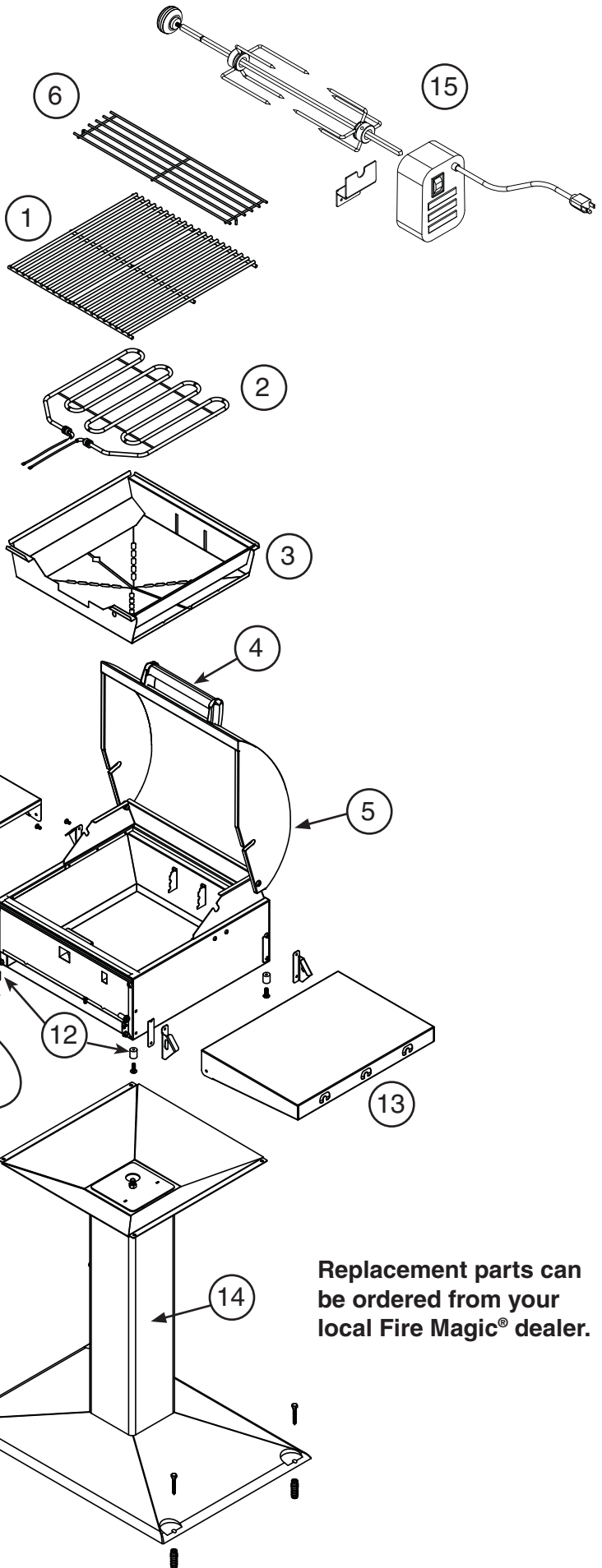

* Countertop models only
 † Pedestal models only
 ‡ Optional accessory

IMPORTANT
 Remove all packing
 material and discard
 prior to use.

Replacement parts can
 be ordered from your
 local Fire Magic® dealer.



WARNING!

When using electrical appliances, basic safety precautions must always be followed including the following:

1. **Read all instructions.**
2. Do not touch hot surfaces, always use the handle.
3. To protect against electrical shock, do not immerse cord, plugs, probe or grill in water or other liquids.
4. Close supervision is necessary when any appliance is used near children.
5. Unplug from outlet when not in use and before cleaning or servicing. Allow to cool before putting on or taking off parts.

Note: After use and shut-off of this unit, **DO NOT** immediately disconnect the electric supply. The electric fan in this unit will continue to operate so that the unit may completely cool. Always allow sufficient cooling time prior to disconnecting the electric supply.

6. Do not operate appliance with a damaged cord or plug or after the appliance malfunctions or has been damaged in any manner. Return appliance to the nearest authorized service facility for examination, repair or adjustment.
7. The use of accessory attachments not recommended by the appliance manufacturer may cause injuries.
8. Do not let cord hang over edge of table or counter, or touch hot surfaces.
9. Do not place on or near a hot gas or electric burner or in a heated oven.
10. Extreme caution must be used when moving an appliance containing hot oil or other hot liquids.
11. To disconnect, turn any controls to OFF, then remove plug from wall outlet.
12. Do not use appliance for other than intended use.
13. Fuel, such as charcoal briquettes, is not to be used with appliance.
14. Use only on a properly grounded outlet (see page 7).
15. NEVER grill in the open rain or in standing water as this grill is an electric appliance. There is always a hazard of electric shock while operating this unit.
16. Keep the appliance area clear and free from combustible materials, gasoline, and other flammable vapors. **WHEN OPERATING THIS UNIT; A MINIMUM 4" CLEARANCE ABOVE (WITH LID OPEN), AND A 4" CLEARANCE ON ALL SIDES MUST BE MAINTAINED.**
17. This appliance does not contain a fuse or surge protector. The power to the unit must be made readily accessible to the operator through means of a line disconnect switch, circuit breaker, and/or easy to reach receptacle. For outdoor installation, the circuit must have ground fault interrupt.
18. Reference the EXTENSION CORD section (page 7) for all specifications.

SAVE THESE INSTRUCTIONS

INSTALLATION REQUIREMENTS

Important: When in operation, this unit must be located with a minimum of 4" clearance above (with lid open) and 4" clearance on all sides.

ENSURING PROPER AIRFLOW

Proper airflow (Fig. 6-1 and Fig. 6-2) **MUST** be maintained for the grill to perform as it was designed. If airflow is blocked, overheating will result. Do not block the 1" (2.5 cm) front air inlet along the bottom of the control panel or more than 75% of the cooking grid surface with pans or griddles.

CAUTION: DO NOT operate the grill with air blowing into or across the rear oven lid vent (Fig. 6-3). This can cause poor performance and/or dangerous overheating. Orient the grill so that any prevailing wind blows against the front of the grill (Fig. 6-1 and Fig. 6-2).

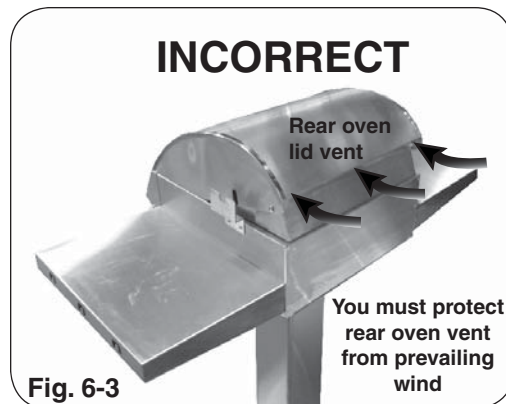
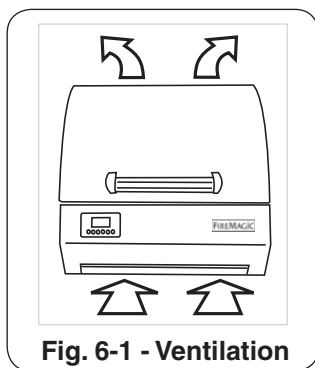

WARNING: NEVER cover the entire cooking or grill surface with griddles or pans. Overheating of the electronic components will occur.

INSTALLATION

COUNTERTOP MODELS

Be sure the unit is stationed on a clean, dry, and level surface, and that all clearance and location requirements on the previous page are met.

PEDESTAL MODELS

Reference the PARTS LIST on page 4 when installing your pedestal electric grill.

1. Using a Phillips screwdriver, remove the four screws and bumpers on the bottom of the grill. Discard the bumpers. Align the electric grill onto the top of the post assembly. Using the same four screws, fasten the electric grill to the post assembly.
2. The post assembly base must be securely fastened to a stable, level surface using the lag screws and shields provided to ensure the grill remains fixed and upright at all times.
3. Remove the four screws on one side of the grill. Align a shelf assembly to the side of the grill. Using the same screws, fasten the shelf to the electric grill. Repeat for the other side.

Important: BEFORE USE, the grill base must be securely fastened to a stable, level surface to ensure the grill remains fixed and upright at all times.

Locate the patio mount base in the planned grill location and mark the 4 holes. Drill the marked holes to a 1/2" diameter x 1 1/2" depth. Insert the lag shields (see PARTS LIST) into the holes, being sure that they are flush with the ground.

Align the holes on the patio mount base over the lag shields in the ground. Secure the base with the lag screws (see PARTS LIST) using a 7/16" nut driver.

INNER LINERS

The inner liners come installed in the unit. To remove for cleaning:

1. Remove the warming rack and cooking grids. Grasp the cool cooking element and apply pressure towards the right of the grill. Once it clears the tab, completely raise it up. Lift the two side liners up and out (Fig. 7-1).
2. Lift the rear liner slightly up to clear the tab, then forward and out (Fig. 7-1).
3. Move the front liner slightly toward the back of the grill, then lift up and out (Fig. 7-1).

Re-installing the liners is the reverse of above. (The order for re-install is front liner, rear liner, then side liners.)

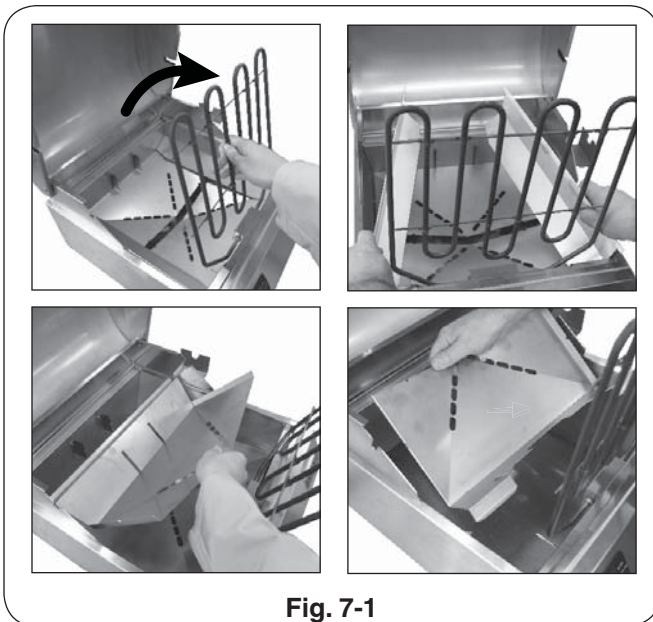

Fig. 7-1

CONNECTING TO ELECTRICAL OUTLET

This electrical appliance is equipped with a three-pronged (grounding) plug for your protection against shock hazard and should be plugged directly into a properly grounded three-prong GFI protected receptacle. Do not cut or remove the grounding prong from the plug. (See Fig. 7-2.)

Do not operate any appliance with a damaged cord or plug, or after an appliance malfunction. Return the appliance to your dealer or authorized service facility for inspection, repair or electrical/mechanical adjustment.

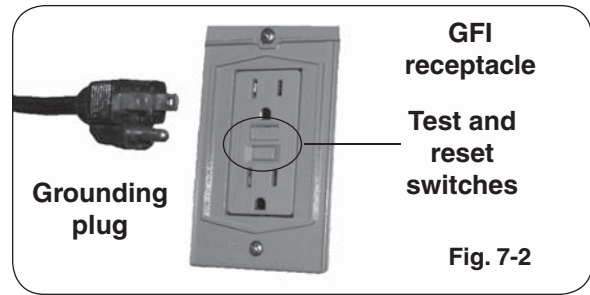

Fig. 7-2

EXTENSION CORDS

Use only a **14-gauge** extension cord, with a 3-prong plug, suitable for use with outdoor appliances. The maximum length allowed for the extension cord is **25 feet**. Do not use damaged extension cords. Examine extension cord before using and replace if damaged. Keep cord away from heat and sharp edges.

Important: Connection to an extension cord shall be kept dry and off the ground.

OPTIONAL ROTISSERIE

If the optional rotisserie has been selected; the rotisserie bracket must be installed prior to use.

1. Using a Phillips screwdriver; remove the 2 screws located towards the rear, right side of the grill.
2. Align the holes of the rotisserie bracket with the exposed screw holes on the grill. Using the screws from step 1, fasten the bracket to the grill (see Fig. 7-3).

Reference the ROTISSERIE section for instructions on how to use the rotisserie.

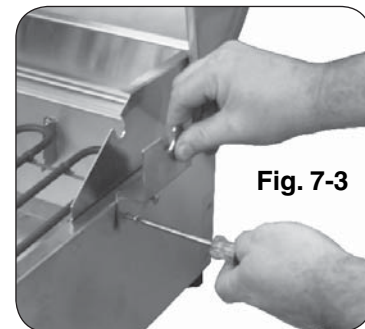
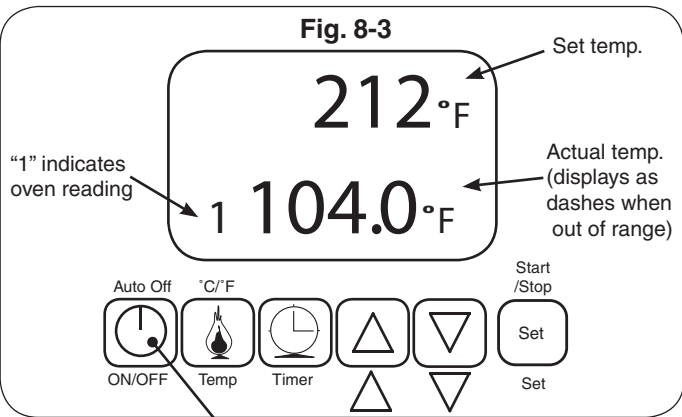
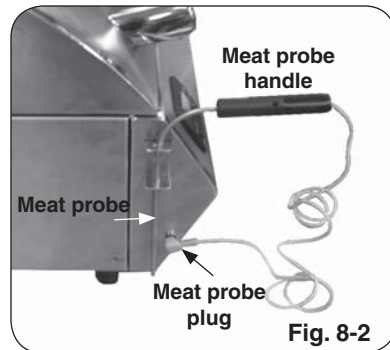

Fig. 7-3

THERMOMETER/THERMOSTAT

Your electric grill is controlled with a digital thermostat, which includes a built-in timer and alarm with auto shut-off after 2 hours. The thermometer is located on the left side of the control panel. Plug in the meat probe as shown in Fig. 8-2. The actual grill temperature will be maintained within a 20 degree (Fahrenheit) differential of the set temperature.

Note: This electric grill will not operate at temperatures below 38° F.



Setting temperature

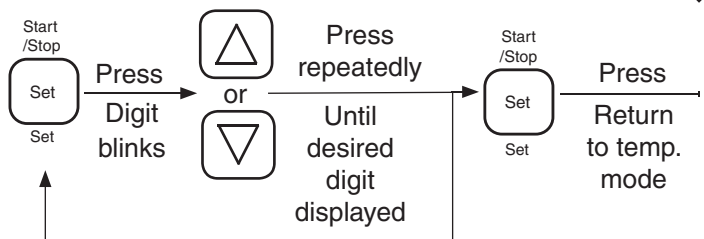

Changing temperature units (Celsius/Fahrenheit)

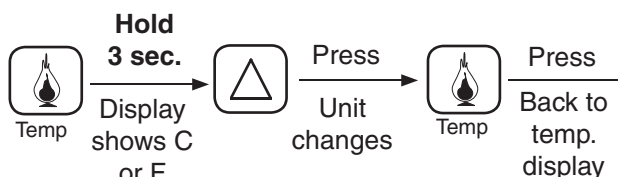

Press to turn electric grill on or off. Once the grill is turned on, the cooking element immediately begins to heat. Set the desired temperature per the diagram to the right.

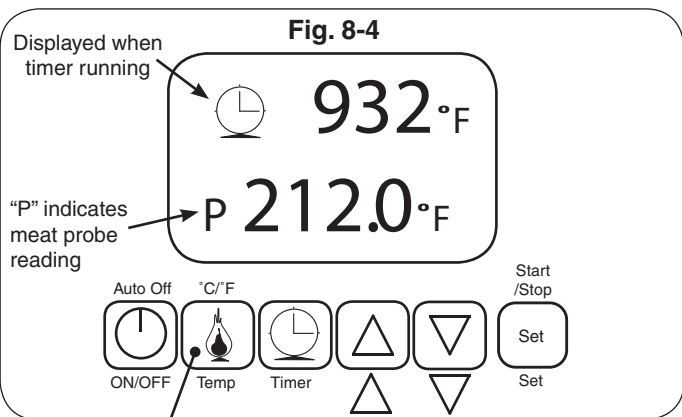

Setting and starting the count-down timer

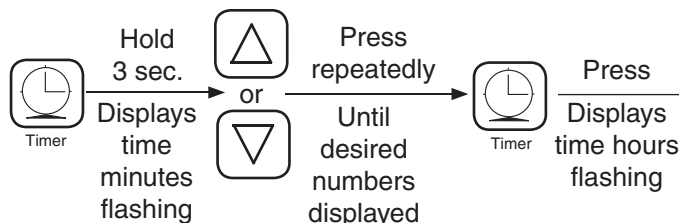

Press once for temp. alternation between probe and oven.

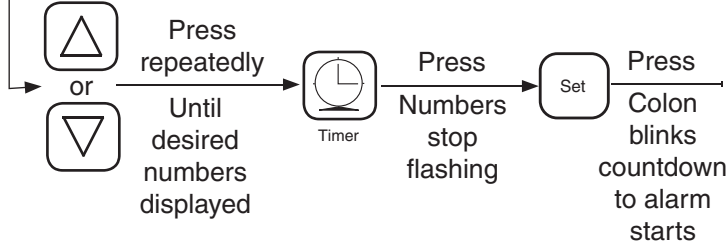
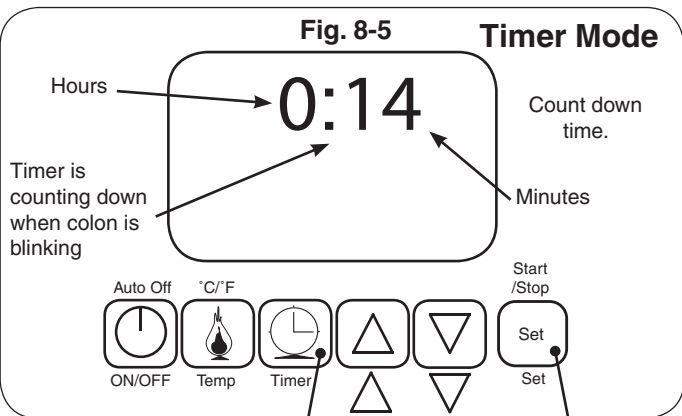

Note: Press any key to silence alarm when beeping. Alarm will not sound if timer is turned off.

Press Temp. to return from timer mode.

The internal clicking sound is normal when operating.

COOKING ELEMENT

The cooking element may be adjusted between three different heights. Be sure the grill is off and completely cool before any adjustments.

1. Remove the warming rack and cooking grids.
2. Grasp the cool cooking element and apply pressure towards the right of the grill. Once it clears the tab, raise or lower it to the desired height. (See Fig. 9-1.) Be sure it securely rests in position.
3. Replace the cooking grids and warming rack.

Important: To prevent overheating, the cooking element must not come in contact with the thermocouple. A nominal clearance of 1/8" must be maintained at all times. (See Fig. 9-2.)

OPTIONAL ROTISSERIE

Be sure the grill is off and completely cool before beginning rotisserie set up.

1. Following steps 1 and 2 above, adjust the cooking element to the lowest position (if necessary).
2. Slide the rotisserie motor fully onto the motor bracket located on the right of the grill (Fig. 9-3).
3. Slide left meat holder into position on rotisserie rod as shown in Fig. 9-4 and tighten screw.
4. Slide meat onto rod and into holder (Figs. 9-4).

Note: To allow proper operation, meat diameters should not exceed 8 inches.

5. Slide right meat holder onto rod and into meat (Fig. 9-4). Tighten thumb screw.
6. Support both ends of the rod so it spins freely. If meat weight is distributed unevenly, the rod will rotate until the heavy side of the meat points downward.
7. Insert the pointed end of the rod into the motor drive socket, and the groove next to the knob into the notch on the left side of the grill.
8. Plug in the rotisserie motor and press the rocker switch to start.

Reference the THERMOMETER section to begin cooking.

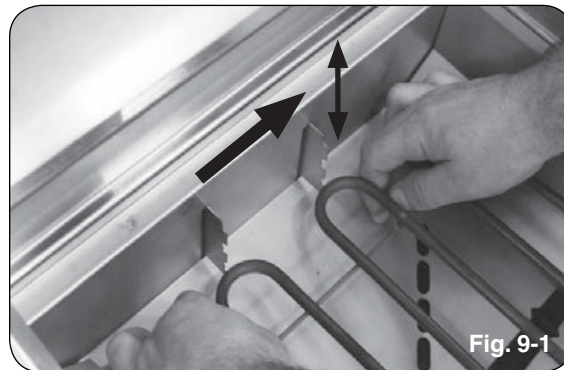

Fig. 9-1

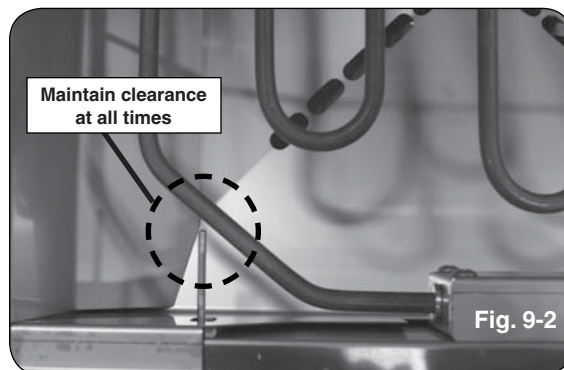

Fig. 9-2

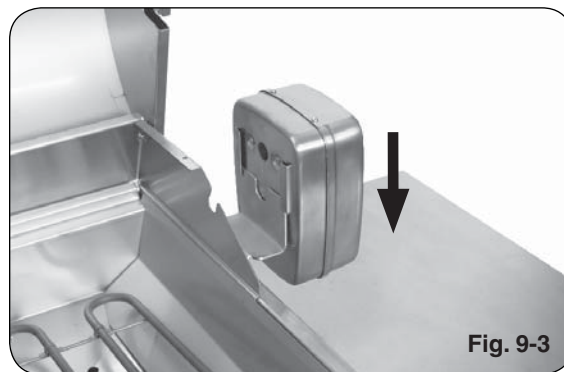

Fig. 9-3

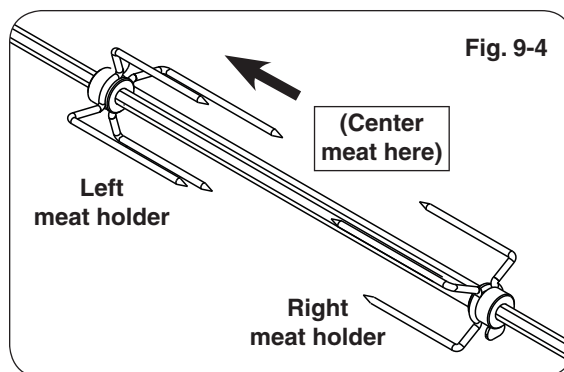
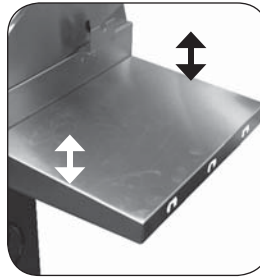

Fig. 9-4

DROP DOWN SHELF

1. To lower the shelf, grab the middle of the shelf on both sides and lift upward. Then allow the end of the shelf to rotate down as pictured to the right.
2. To raise the shelf, grab the middle of the shelf on both sides and raise it to the horizontal position. Lift slightly upward, and lock the shelf safely into position.

CAUTION: Do **NOT** place fingers near hinge when closing.



Shelf
up & locked

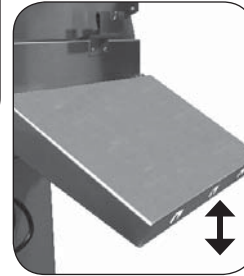

Being
lowered or
raised

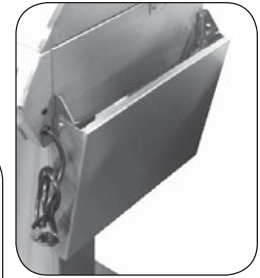

Shelf
down



Fig. 11-2

Pull out the drip tray



Fig. 11-3

Center drip tray liner into drip tray

Drippings from grilling flow through specially designed channels and collect in the drip tray. Check the drip tray regularly and empty when required.

Fig. 11-1



Your grill includes a sample Fire Magic® drip tray liner (Fig. 11-1). For your convenience in cleanup, place the liner into the drip tray before grilling.

To fit a liner into the drip tray, pull out the tray (Fig. 11-2). Place the liner in the drip tray as shown in Fig. 11-3 and carefully slide the tray back into the control panel.

Note: Be sure to center the liner in the drip tray, so that it may provide complete coverage under all of the openings in the grill.

After each use, wait for the grill to cool and carefully pull out the drip tray to check it. When the liner is nearing full, carefully lift it out of the drip tray, lifting with both hands to keep the tray level until it is safely discarded.

Order more drip tray liners through your local Fire Magic® dealer.

CARE AND CLEANING

APPLIANCE MUST BE COMPLETELY COOL WHEN CLEANING. DO NOT SPRAY ANY CLEANER OR LIQUIDS ON THE APPLIANCE WHEN HOT.

Stainless steel surfaces when exposed to temperatures produced by the grilling process will change color. The stainless steel will change color from silver to brown and blue. This can be removed by using Fire Magic Stainless Steel Cleaner (3581-1).

Clean your appliance by first using Fire Magic Barbecue and Grill Cleaner (part #3580-1) to remove grease and dirt. Always wipe with the grain (See Fig. 12-1). Next, use Fire Magic Stainless Steel Cleaner (3581-1) to restore the stainless steel color (Note: not for mirror finish). Finish by wiping your appliance down using Fire Magic Polish Wipes (3586-1). **To clean the mirror panel (if applicable), use a quality brand glass cleaner only, not any of the cleaners mentioned above.**

Clean your appliance at least once a month.

If your appliance is installed in a seaside (salt air) or poolside (chlorine) location, it will be more susceptible to corrosion and must be maintained/cleaned more frequently. Do not store chemicals (such as chlorine or fertilizer) near your stainless steel appliance.

Due to the nature of stainless steel, surface iron oxide deposits may appear. Do not be alarmed – these deposits are removable with stainless-steel cleaner through prompt and periodic maintenance. If not attended to promptly, permanent pitting may occur.

Periodically clean the drip tray and inner liners of all food/grease deposits to reduce the chance of fire and assure proper operation. The drip tray and inner liners are removable for hand or dishwasher cleaning. Reference the INSTALLATION section for inner liner details. The cooking element does not need cleaning.

The inside of the appliance may be cleaned periodically with oven cleaner if desired. Follow the oven cleaner instructions for proper use.

Be careful not to get oven cleaner on the outside surface of the appliance as it can permanently damage the finish.

By following these recommendations, you will enjoy the beauty and convenience of your appliance for many years to come.



Fig. 12-1 - Wipe with grain

PROTECTING YOUR APPLIANCE FROM THE WEATHER

An optional heavy-duty cover will protect your appliance's finish and protect your investment. The water repellent cover will protect your appliance from the weather. Always cover your appliance when not in use. (Allow to cool before covering.)

Please specify the model number and serial number of your appliance when ordering a cover.

TROUBLESHOOTING

If you have trouble with this Fire Magic® grill, please use this list to identify the problem. By trying one or more of the solutions to the possible cause, you should be able to solve the problem. If this list does not cover your present problem, or if you have other technical difficulties with the grill, please contact your local Fire Magic® dealer or visit our web site at www.rhpeterson.com.

PROBLEM	POSSIBLE CAUSE	CORRECTION
Grill does not work	1. Power failure 2. Power not plugged correctly 3. GFI plug may be tripped	1. Check if power is available. 2. Make sure the power cord plug is properly inserted into the receptacle. 3. Reset switches on the GFI receptacle.
Thermometer does not work	1. No power to unit 2. Faulty component	1. Assure power is available. 2. Contact your dealer.
Cooking element does not work	1. No power to unit 2. Bad element	1. Assure power is available. 2. Contact your dealer.

Table 2

WARRANTY

TEN-YEAR WARRANTY - Fire Magic® stainless-steel rod cooking grids and stainless-steel housings are warranted for ten (10) years from the date of purchase of your grill.

THREE-YEAR WARRANTY - All other Fire Magic® grill components (except ignition and electronic parts) are warranted for three (3) years from the date of purchase of your Fire Magic® grill.

Fire Magic® ignition systems (excluding batteries), electronic components (including lights and thermometers), and accessories are warranted for one (1) year from date of purchase.

PLEASE KEEP A COPY OF YOUR SALES SLIP FOR PROOF OF PURCHASE

This warranty applies to the original purchaser and to single family residential use only. It commences from date of purchase, and is valid only with proof of purchase.

This warranty does not cover parts becoming defective through misuse, accidental damage, electrical damage, lack of routine maintenance, improper handling, storage, and/or installation. Product must be installed as specified in the instructions or operator's manual, by a **qualified professional installer**. Accessories, parts, valves, remotes, etc., when used must be Peterson Co. product.

This warranty **does not** apply to rust, corrosion, oxidation, or discoloration, unless the affected component becomes inoperable. It **does not** cover labor or labor-related charges.

This warranty specifically excludes liability for **indirect, incidental**, or consequential damages. Some states do not allow the exclusion or limitation of incidental or consequential damages, so the above exclusion may not apply to you. This warranty gives you specified legal rights, and you may have other rights that may vary from state to state.

For additional information regarding this warranty, or to place a warranty claim, contact the R.H. Peterson dealer where the product was purchased.

**TO REGISTER YOUR PRODUCT ONLINE GO TO: WWW.RHPETERSON.COM,
AND CLICK ON PRODUCT REGISTRATION. THANK YOU FOR YOUR PURCHASE.**

Quality Check	Date: _____
Electrical Leak Test: _____	Burn Test: _____
Model#: _____	Serial#: _____
Inspector: _____	